



E9*10R06/02*23713*00

Página/ Page 1/ 3

Comunicación sobre/ *Communication concerning the:*

- homologación/ *approval granted*
- extensión de una homologación/ *approval extended*
- denegación de una homologación/ *approval refused*
- retirada de una homologación/ *approval withdrawn*
- cese definitivo de homologación/ *production definitely discontinued*

de un tipo de subconjunto ~~eléctrico~~/ electrónico en aplicación del Reglamento nº 10/ *of a type of electrical/ electronic sub-assembly with regard to ECE Regulation No. 10*

Nº de homologación/ *Type-approval N.º:* E9*10R06/02*23713*00

Nº de extensión/ *Extension No.:* --

SECCION I/ *SECTION I*

1. Marca (razón social)/ *Make (trade name of manufacturer):*
BORY AUTO LIGHT
2. Tipo y denominación(es) comercial (es)/ *Type and general commercial description(s):*
Tipo / *Type:* BR0103601 SERIES
Variantes / *Variants:* Ver documentación aportada/ *See technical documentation*
Denominación comercial / *Commercial description:* Special Warning Lamp/Signal Lamp
3. Medio de identificación del tipo, si está marcado en el ~~vehículo~~, el componente o la ~~unidad técnica independiente~~/ *Means of identification of type, if marked on the vehicle, component or separate technical unit:* Ver documentación aportada/ *See technical documentation*
- 3.1. Emplazamiento de estas marcas/ *Location of that marking:* Ver documentación aportada/ *See technical documentation*
4. Categoría de vehículo/ *Category of vehicle:* --
5. Nombre y dirección del fabricante/ *Name and address of manufacturer:*
Guangzhou Bory Auto Light Co., Ltd.
4/F, Building 8, No.2 Ke'er Road(Self compiled), Dongyong Town, Nansha District, Guangzhou, Guangdong 511443, China.
6. Emplazamiento y forma de colocación de la marca de homologación CEE en componentes y unidades técnicas independientes/ *In the case of components and separate technical units, location and method of affixing of the approval mark:* Ver documentación aportada/ *See technical documentation*
7. Dirección(es) de la(s) planta(s) de montaje/ *Address(es) of assembly plant(s):*
Guangzhou Bory Auto Light Co., Ltd.
4/F, Building 8, No.2 Ke'er Road(Self compiled), Dongyong Town, Nansha District, Guangzhou, Guangdong 511443, China.





E9*10R06/02*23713*00

Página/ Page 2/ 3

8. Información complementaria (si procede)/ *Additional information (where applicable): Véase el apéndice/ See appendix*
9. Servicio técnico encargado de la realización de los ensayos/ *Technical service responsible for carrying out the tests: IDIADA*
10. Fecha del acta de ensayo/ *Date of test report: 08/06/2023*
11. Número del acta de ensayo/ *Number of test report: CN23060007*
12. Observaciones (si las hubiera) / *Remarks (if any): Véase el apéndice/ See appendix*
13. Lugar/ *Place: MADRID*
14. Fecha/ *Date: Ver firma electrónica/ See electronic signature*
15. Firma/ *Signature:*

SUBDIRECTOR GENERAL DE CALIDAD Y SEGURIDAD INDUSTRIAL
Resolución P.D. del DIRECTOR GENERAL DE INDUSTRIA Y DE LA PYME de 25-10-2012
16. Se adjunta el índice del expediente de homologación en posesión de las autoridades competentes, la cual puede obtenerse a petición del interesado/ *The index to the information package lodged with the approval authority, which may be obtained on request is attached*
17. Motivos de extensión/ *Reasons for extension: --*





E9*10R06/02*23713*00

Página/ Page 3/ 3

Apéndice del certificado de homologación N° / Appendix to Type-approval communication form No.

E9*10R06/02*23713*00

**relativo a la homologación de subconjuntos eléctricos o electrónicos en lo que se refiere al Reglamento N°10/
concerning the type-approval of an electrical/electronic sub-assembly under Regulation N° 10**

1. Información adicional/ *Additional information (where applicable):*
 - 1.1. Tensión nominal del sistema eléctrico/ *Electrical system rated voltage: Ver documentación aportada/ See technical documentation*
 - 1.2. Este SEE puede utilizarse en todos los vehículos con las siguientes restricciones/ *This ESA can be used on any vehicle type with the following restrictions: Ver documentación aportada/ See technical documentation*
 - 1.2.1. Condiciones de instalación, si las hubiera/ *Installation conditions, if any: Ver documentación aportada/ See technical documentation*
 - 1.3. Este SEE sólo puede utilizarse en los tipos de vehículo siguientes/ *This ESA can only be used on the following vehicle types: ---*
 - 1.3.1. Condiciones de instalación si las hubiera/ *Installation conditions, if any: ---*
 - 1.4. El método o métodos específicos de ensayo utilizados y los márgenes de frecuencias abarcados para determinar la inmunidad han sido/ *The specific test method(s) used and the frequency ranges covered to determine immunity were: 20-2000MHz*
 - 1.5. Laboratorio acreditado según ISO 17025 y reconocido por el organismo homologador responsable de realizar los ensayos/ *Laboratory accredited to ISO 17025 and recognized by the Approval Authority responsible for carrying out the tests: IDIADA or LGAI*
2. Observaciones/ *Remarks (if any): ---*





Anexo - Información adicional sobre esta Homologación de tipo

Condiciones de la autorización y pie de recurso

Los vehículos, sistemas, componentes o unidades técnicas independientes fabricados en virtud de esta homologación de tipo deben estar identificados y portar las marcas correspondientes según la reglamentación aplicable.

La producción en serie de vehículos, sistemas, componentes y unidades técnicas independientes debe realizarse de acuerdo con la documentación de homologación. Todo cambio en la producción individualizada requerirá autorización expresa previa por parte de la Autoridad de Homologación Española.

Cualquier modificación en los datos incluidos en el certificado de homologación, como el nombre de la empresa, representante en la UE, dirección y las plantas de fabricación deben ser comunicados inmediatamente a la Autoridad de Homologación Española.

La homologación perderá su validez cuando la misma haya sido retirada o el tipo ya no cumpla con los requisitos legales. La retirada tendrá lugar siempre que hayan dejado de cumplirse los requisitos necesarios para la concesión y mantenimiento de la misma, cuando el fabricante no pueda demostrar a la Autoridad de Homologación el cumplimiento con los requisitos y procedimientos para garantizar la conformidad de la producción, en caso de que el titular no cumpla con sus obligaciones inherentes a la homologación o cuando se determine que el tipo homologado no cumple con los requisitos de seguridad y medio ambiente.

La Autoridad de Homologación de Tipo española podrá verificar el cumplimiento de las obligaciones del fabricante en cualquier momento. En particular, se podrá comprobar la correspondencia del producto con el tipo homologado, así como las medidas establecidas para garantizar la conformidad de la producción. A tal efecto se podrán tomar o solicitar las muestras necesarias. Se permitirá el acceso sin trabas a las instalaciones de producción y almacenamiento a los empleados o representantes de la Autoridad de Homologación Española.

La autorización objeto de esta resolución de homologación de tipo no es transferible. Los derechos de marca de terceros no se encuentran afectados por esta homologación.

Contra la presente Resolución, que no pone fin a la vía administrativa, podrá interponerse recurso de alzada ¹ ante la Dirección General de Industria y de la Pequeña y Mediana empresa, o ante la Secretaría General de Industria y de la Pequeña y Mediana empresa, en el plazo de un mes a partir del día siguiente a su notificación, de conformidad con los artículos 121 y 122 de la Ley 39/2015, de 1 de octubre, del Procedimiento Administrativo Común de las Administraciones Públicas.

¹ Nota: Para interponer recurso de alzada deberá acceder al siguiente enlace:
<https://sede.serviciosmin.gob.es/es-es/procedimientoselectronicos/Paginas/detalle-procedimientos.aspx?IdProcedimiento=157>





Annex - Additional Information on this Type Approval

Collateral clauses and right to appeal (Courtesy translation)

All vehicles, systems, components or separate technical units which correspond to the approved type are to be identified and marked according to the applied regulation.

The serial fabrication of vehicles, systems, components or separate technical must be in exact accordance with the approval documents. Changes in the individual production are only allowed with express consent of the Spanish Type Approval Authority.

Changes in the data included in the approval certificate, such as the name of the company, EU representative, address and the manufacturing plant are to be immediately disclosed to the Spanish Type Approval Authority.

The approval expires if it is withdrawn or if the type approved no longer complies with the legal requirements. The revocation can be made if the demanded requirements for issuance and the continuance of the approval no longer exist, if the manufacturer cannot demonstrate to the Type Approval Authority that it comply with the requirements and procedures to guarantee the conformity of production, if the holder of the approval violates the duties involved in the approval or if it is determined that the approved type does not comply with the requirements of traffic safety or environmental protection.

The Spanish Type Approval Authority may check the proper exercise of the conferred authority taken from this approval at any time. In particular, this means the compliant production as well as the measures for conformity of production. For this purpose, samples can be taken or have taken. The employees or the representatives of the Spanish Type Approval Authority may get unhindered access to the production and storage facilities.

The authorization contained with issuance of this approval is not transferable. Trade mark rights of third parties are not affected with this approval.

This approval does not conclude the administrative channel and can be appealed² within one month after notification, according to articles 121 and 122 of Ley 39/2015, de 1 de octubre, del Procedimiento Administrativo Común de las Administraciones Públicas. The appeal is to be addressed to Dirección General de Industria y de la Pequeña y Mediana empresa, or Secretaría General de Industria y de la Pequeña y Mediana empresa.

² Note: Appeal on the following link:

<https://sede.serviciosmin.gob.es/es-es/procedimientoselectronicos/Paginas/detalle-procedimientos.aspx?IdProcedimiento=157>



**INFORME/ REPORT N° CN23060007****REGLAMENTO UN N° 10R06/02 REFERENTE A LA COMPATIBILIDAD ELECTROMAGNÉTICA
UN REGULATION No. 10R06/02 RELATING ELECTROMAGNETIC COMPATIBILITY****INFORMACIÓN GENERAL/
GENERAL INFORMATION**

Solicitante/ <i>Applicant</i>	: Guangzhou Bory Auto Light Co., Ltd.
Fabricante/ <i>Manufacturer</i>	: Guangzhou Bory Auto Light Co., Ltd. 4/F, Building 8, No.2 Ke'er Road(Self compiled), Dongyong Town, Nansha District, Guangzhou, Guangdong 511443, China.
Marca/ <i>Make</i>	: BORY AUTO LIGHT
Tipo/ <i>Type</i>	: BR0103601 SERIES
Denominación comercial/ <i>Commercial description</i>	: Special Warning Lamp/Signal Lamp
Categoría/ <i>Category</i>	: Sistemas y componentes/ <i>Systems and components</i>
Lugar y fecha de emisión del informe/ <i>Place and date of report issue</i>	: L'Albornar, Santa Oliva (Tarragona), 18/06/2023

CONCLUSIONES: Este a componente/~~unidad técnica independiente~~ CUMPLE con las prescripciones sobre compatibilidad electromagnética relativo al REGLAMENTO UN N° 10R06/02, como se detalla en el anexo a este informe.

CONCLUSIONS: This component/~~separate technical unit~~ FULFILS the prescriptions about electromagnetic compatibility, in application to UN REGULATION 10R06/02, as detailed in the annex to this report.

Realizado / *Performed by*V. B°./ *Revised by:*Juxiang(lyrica) Chen
INGENIERO DE HOMOLOGACIONES
HOMOLOGATION ENGINEERJosep Masip Gomez
JEFE DE DEPARTAMENTO
DEPARTMENT MANAGER

- * LOS RESULTADOS PRESENTADOS SE REFIEREN ÚNICAMENTE A LA MUESTRA ENSAYADA.
THE PRESENTED RESULTS REFER ONLY TO THE TESTED SAMPLE.
- * QUEDA TERMINANTEMENTE PROHIBIDA LA REPRODUCCIÓN PARCIAL DE ESTE INFORME SIN PERMISO EXPRESO DE IDIADA.
THE PARTIAL REPRODUCTION OF THIS REPORT WITHOUT THE PERMISSION OF IDIADA IS COMPLETELY FORBIDDEN.
- * EL LABORATORIO HA CALCULADO LA INCERTIDUMBRE DE MEDIDA ASOCIADA A LOS RESULTADOS.
MEASUREMENT UNCERTAINTY OF THE RESULTS HAS BEEN CALCULATED BY THE LABORATORY.



ANEXO AL INFORME

ANNEX TO THE REPORT

1. CARACTERISTICAS DEL SUBCONJUNTO ELECTRICO-ELECTRONICO/
ELECTRICAL-ELECTRONIC SUB-ASSEMBLY CHARACTERISTICS

Marca/ *Make*⁽¹⁾ : BORY AUTO LIGHT

Tipo/ *Type*⁽¹⁾ : BR0103601 SERIES

Variants : BR01036XX(XX:00~99)

Denominación comercial/
Commercial description⁽¹⁾ : Special Warning Lamp/Signal Lamp

Categoría/ *Category* : Sistemas y componentes/ *Systems and components*

Muestra de ensayo/ *Test Sample* : BR0103601

⁽¹⁾ Información proporcionada por el cliente. El laboratorio no se hace responsable de dicha información /
Information provided by the client. The laboratory is not responsible for such information

Sample	Reference	Description	Sample Id. No.
#1	12V/24V	BR0103601	Q2305176-001

Equipo auxiliar/ *Auxiliary equipment* :

Sample	Reference	Description	Sample Id. No.
#1	NA	NA	NA

Fecha de recepción de la muestra/
Test sample reception date : 25/05/2023

Fecha inicial de los ensayos/
Test initial date : 08/06/2023

Fecha final de los ensayos/
Test final date : 08/06/2023

Lugar de los ensayos/ *Test site* : SQT, Guanzhou(China)

* LOS RESULTADOS PRESENTADOS SE REFIEREN ÚNICAMENTE A LA MUESTRA ENSAYADA.
THE PRESENTED RESULTS REFER ONLY TO THE TESTED SAMPLE.

* QUEDA TERMINANTEMENTE PROHIBIDA LA REPRODUCCIÓN PARCIAL DE ESTE INFORME SIN PERMISO EXPRESO DE IDIADA.
THE PARTIAL REPRODUCTION OF THIS REPORT WITHOUT THE PERMISSION OF IDIADA IS COMPLETELY FORBIDDEN.

* EL LABORATORIO HA CALCULADO LA INCERTIDUMBRE DE MEDIDA ASOCIADA A LOS RESULTADOS.
MEASUREMENT UNCERTAINTY OF THE RESULTS HAS BEEN CALCULATED BY THE LABORATORY.

* LA REGLA DE DECISIÓN UTILIZADA, SEGÚN LA NORMA ILAC-G8, HA SIDO LA DECLARACIÓN BINARIA DE ACEPTACIÓN SIMPLE
THE DECISION RULE USED, ACCORDING TO THE ILAC-G8 STANDARD, WAS THE BINARY STATEMENT FOR SIMPLE ACCEPTANCE



Fotos/ Photos:



(Foto de la muestra/ Sample photo)

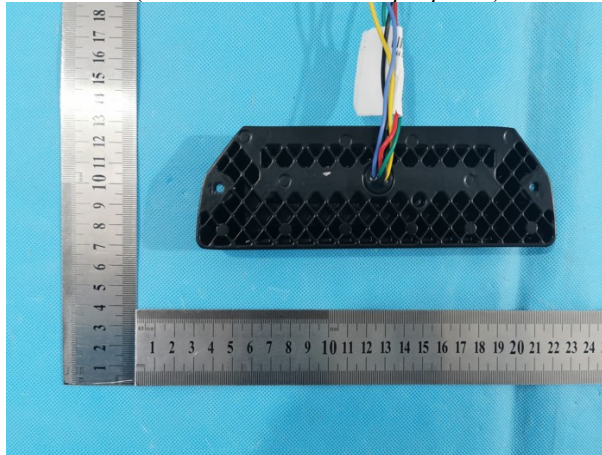

(Foto de la etiqueta de identificación/ Label identification photo)

Alimentación/ Power supply : DC 12V/24V

Relacionado con funciones de inmunidad/
Related to immunity functions : Si-~~No~~/ Yes-~~No~~

Modos de funcionamiento/ Operation modes :

Operation Mode	Description
OM#1	Normal operation

* LOS RESULTADOS PRESENTADOS SE REFIEREN ÚNICAMENTE A LA MUESTRA ENSAYADA.
THE PRESENTED RESULTS REFER ONLY TO THE TESTED SAMPLE.
* QUEDA TERMINANTEMENTE PROHIBIDA LA REPRODUCCIÓN PARCIAL DE ESTE INFORME SIN PERMISO EXPRESO DE IDIADA.
THE PARTIAL REPRODUCTION OF THIS REPORT WITHOUT THE PERMISSION OF IDIADA IS COMPLETELY FORBIDDEN.
* EL LABORATORIO HA CALCULADO LA INCERTIDUMBRE DE MEDIDA ASOCIADA A LOS RESULTADOS.
MEASUREMENT UNCERTAINTY OF THE RESULTS HAS BEEN CALCULATED BY THE LABORATORY.
* LA REGLA DE DECISIÓN UTILIZADA, SEGÚN LA NORMA ILAC-G8, HA SIDO LA DECLARACIÓN BINARIA DE ACEPTACIÓN SIMPLE
THE DECISION RULE USED, ACCORDING TO THE ILAC-G8 STANDARD, WAS THE BINARY STATEMENT FOR SIMPLE ACCEPTANCE

IDIADA Automotive Technology, S.A. N.I.F. A43581610 Servicio Técnico Designado de Homologación (TS)



2. ENSAYOS EN CONFIGURACIONES DISTINTAS DE LA DE «MODO DE CARGA DEL REESS ACOPLADO A LA RED ELÉCTRICA»/ TESTS IN CONFIGURATIONS OTHER THAN “REESS CHARGING MODE COUPLED TO THE POWER GRID”

2.1. EMISIONES RADIADAS/ RADIATED EMISSIONS

Método de ensayo/ Test method :

Test	Regulation	Annex
Broadband radiated emissions (BB)	UN REGULATION No. 10R06/02	7
Narrowband radiated emissions (NB)	UN REGULATION No. 10R06/02	8

Muestra de ensayo/ Test Sample :

Sample	Reference	Description	Sample Id. No.
#1	12V/24V	BR0103601	Q2305176-001

Equipo auxiliar/ Auxiliary equipment :

Sample	Reference	Description	Sample Id. No.
#1	NA	NA	NA

Condiciones ambientales/ Environmental conditions :

Temperature (°C)	Humidity (%)	Atm. Pressure (mbar)
23.8	56.2	--

Límites/ Limits :

Bandwidth	Broadband radiated emissions (BB)		
	Limit L (dBuV/m) in function of the frequency f (MHz)		
	Detector type: Peak		
	Frequency range		
120 kHz	30-75 MHz L=62-25.13log(f/30)	75-400 MHz L=52+15.13log(f/75)	400 MHz – 1 GHz L=63

Si se utilizan detectores de picos, se aplica un factor de corrección de 20 dB tal como se define en CISPR 12./ If peak detectors are used a correction factor of 20 dB as defined in CISPR 12 is applied.

Narrowband radiated emissions (NB) Limit (dBµV/m)		
30-75 MHz	75-400 MHz	400 MHz – 1 GHz
L=52-25.13log(f/30)	L=42+15.13log(f/75)	L=53

* LOS RESULTADOS PRESENTADOS SE REFIEREN ÚNICAMENTE A LA MUESTRA ENSAYADA.
THE PRESENTED RESULTS REFER ONLY TO THE TESTED SAMPLE.
* QUEDA TERMINANTEMENTE PROHIBIDA LA REPRODUCCIÓN PARCIAL DE ESTE INFORME SIN PERMISO EXPRESO DE IDIADA.
THE PARTIAL REPRODUCTION OF THIS REPORT WITHOUT THE PERMISSION OF IDIADA IS COMPLETELY FORBIDDEN.
* EL LABORATORIO HA CALCULADO LA INCERTIDUMBRE DE MEDIDA ASOCIADA A LOS RESULTADOS.
MEASUREMENT UNCERTAINTY OF THE RESULTS HAS BEEN CALCULATED BY THE LABORATORY.
* LA REGLA DE DECISIÓN UTILIZADA, SEGÚN LA NORMA ILAC-G8, HA SIDO LA DECLARACIÓN BINARIA DE ACEPTACIÓN SIMPLE
THE DECISION RULE USED, ACCORDING TO THE ILAC-G8 STANDARD, WAS THE BINARY STATEMENT FOR SIMPLE ACCEPTANCE



Resultados de ensayo/ *Test results* :

Sample	Operation Mode	Frequency range	Polarization	Result
#1	OM#1	30 MHz – 300 MHz	Horizontal	PASS/FAIL
			Vertical	PASS/FAIL
		300 MHz – 1 GHz	Horizontal	PASS/FAIL
			Vertical	PASS/FAIL

THE TESTS HAVE BEEN CARRIED OUT BY IDIADA AUTOMOTIVE TECHNOLOGY, S.A. (TS) LABORATORY ACCREDITED BY ENAC WITH NUMBER OF ACCREDITATION 35/LE2694
 LOS ENSAYOS HAN SIDO REALIZADOS POR IDIADA AUTOMOTIVE TECHNOLOGY, S.A. (TS) ACREDITADO POR ENAC CON NÚMERO DE ACREDITACIÓN 35/LE2694

Validate this report with the security code «1LGN2IW6» at: <https://extranet.idiada.com/hom-cve>
 Verifique el informe con código de seguridad «1LGN2IW6» en: <https://extranet.idiada.com/hom-cve>

CN23060007

* LOS RESULTADOS PRESENTADOS SE REFIEREN ÚNICAMENTE A LA MUESTRA ENSAYADA.
THE PRESENTED RESULTS REFER ONLY TO THE TESTED SAMPLE.

* QUEDA TERMINANTEMENTE PROHIBIDA LA REPRODUCCIÓN PARCIAL DE ESTE INFORME SIN PERMISO EXPRESO DE IDIADA.
THE PARTIAL REPRODUCTION OF THIS REPORT WITHOUT THE PERMISSION OF IDIADA IS COMPLETELY FORBIDDEN.

* EL LABORATORIO HA CALCULADO LA INCERTIDUMBRE DE MEDIDA ASOCIADA A LOS RESULTADOS.
MEASUREMENT UNCERTAINTY OF THE RESULTS HAS BEEN CALCULATED BY THE LABORATORY.

* LA REGLA DE DECISIÓN UTILIZADA, SEGÚN LA NORMA ILAC-G8, HA SIDO LA DECLARACIÓN BINARIA DE ACEPTACIÓN SIMPLE
THE DECISION RULE USED, ACCORDING TO THE ILAC-G8 STANDARD, WAS THE BINARY STATEMENT FOR SIMPLE ACCEPTANCE



Gráficos/ Graphs

12V Horizontal

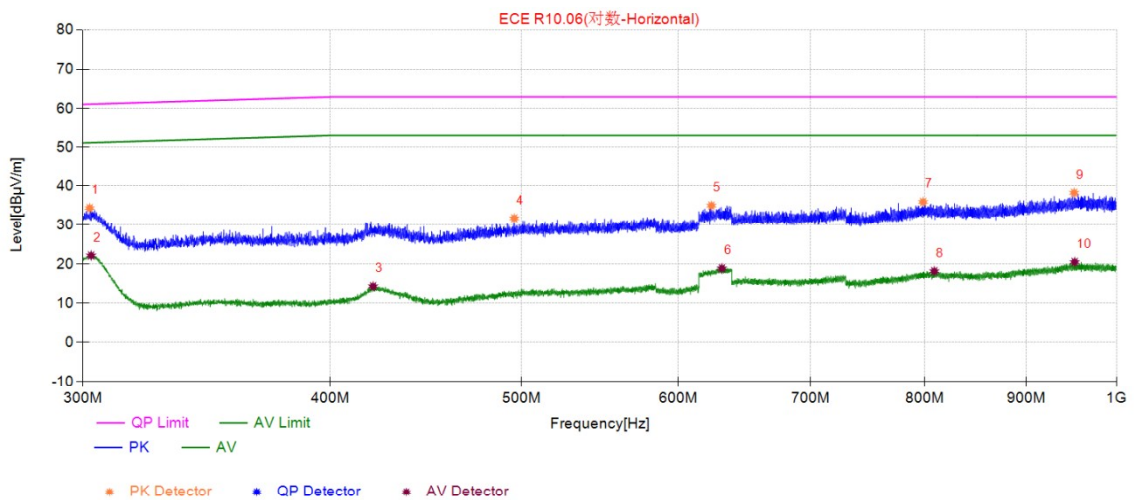
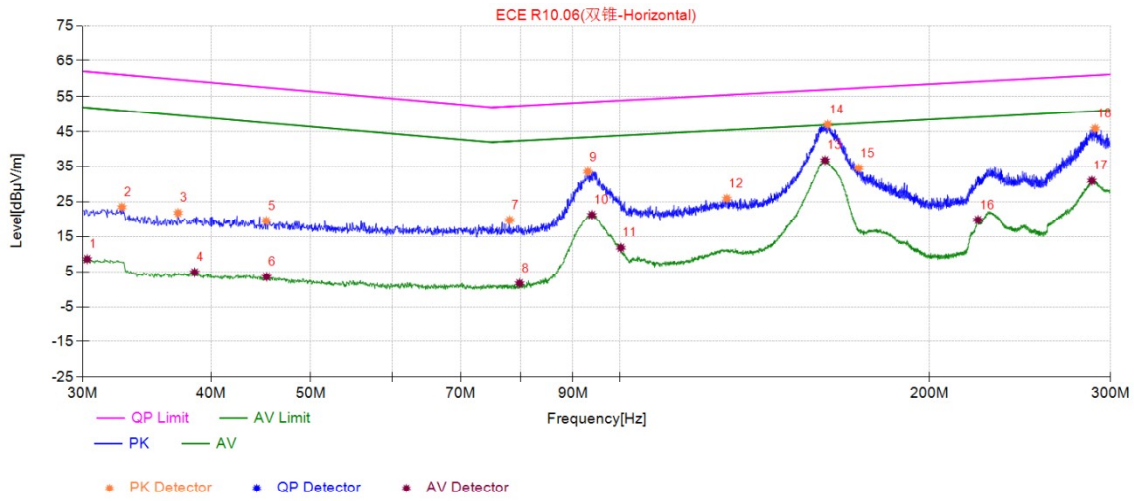

Above results show peak data and average data below the limit. The ESA is deemed to conform to the requirements in respect of this frequency band according to 6.6.2.2. of Regulation 10.06/ECE.

THE TESTS HAVE BEEN CARRIED OUT BY IDIADA AUTOMOTIVE TECHNOLOGY, S.A. (TS) LABORATORY ACCREDITED BY ENAC WITH NUMBER OF ACCREDITATION 35/LE2594
 LOS ENSAYOS HAN SIDO REALIZADOS POR IDIADA AUTOMOTIVE TECHNOLOGY, S.A. (TS) ACREDITADO POR ENAC CON NÚMERO DE ACREDITACIÓN 35/LE2594

Validate this report with the security code «1LGN2IW8» at: <https://extranet.idiada.com/hom-cve>
 Verifique el informe con código de seguridad «1LGN2IW8» en: <https://extranet.idiada.com/hom-cve>

CN23060007

IDIADA

* LOS RESULTADOS PRESENTADOS SE REFIEREN ÚNICAMENTE A LA MUESTRA ENSAYADA.
 THE PRESENTED RESULTS REFER ONLY TO THE TESTED SAMPLE.
 * QUEDA TERMINANTEMENTE PROHIBIDA LA REPRODUCCIÓN PARCIAL DE ESTE INFORME SIN PERMISO EXPRESO DE IDIADA.
 THE PARTIAL REPRODUCTION OF THIS REPORT WITHOUT THE PERMISSION OF IDIADA IS COMPLETELY FORBIDDEN.
 * EL LABORATORIO HA CALCULADO LA INCERTIDUMBRE DE MEDIDA ASOCIADA A LOS RESULTADOS.
 MEASUREMENT UNCERTAINTY OF THE RESULTS HAS BEEN CALCULATED BY THE LABORATORY.
 * LA REGLA DE DECISIÓN UTILIZADA, SEGÚN LA NORMA ILAC-G8, HA SIDO LA DECLARACIÓN BINARIA DE ACEPTACIÓN SIMPLE
 THE DECISION RULE USED, ACCORDING TO THE ILAC-G8 STANDARD, WAS THE BINARY STATEMENT FOR SIMPLE ACCEPTANCE

IDIADA Automotive Technology, S.A. N.I.F. A43581610 Servicio Técnico Designado de Homologación (TS)



12V Vertical

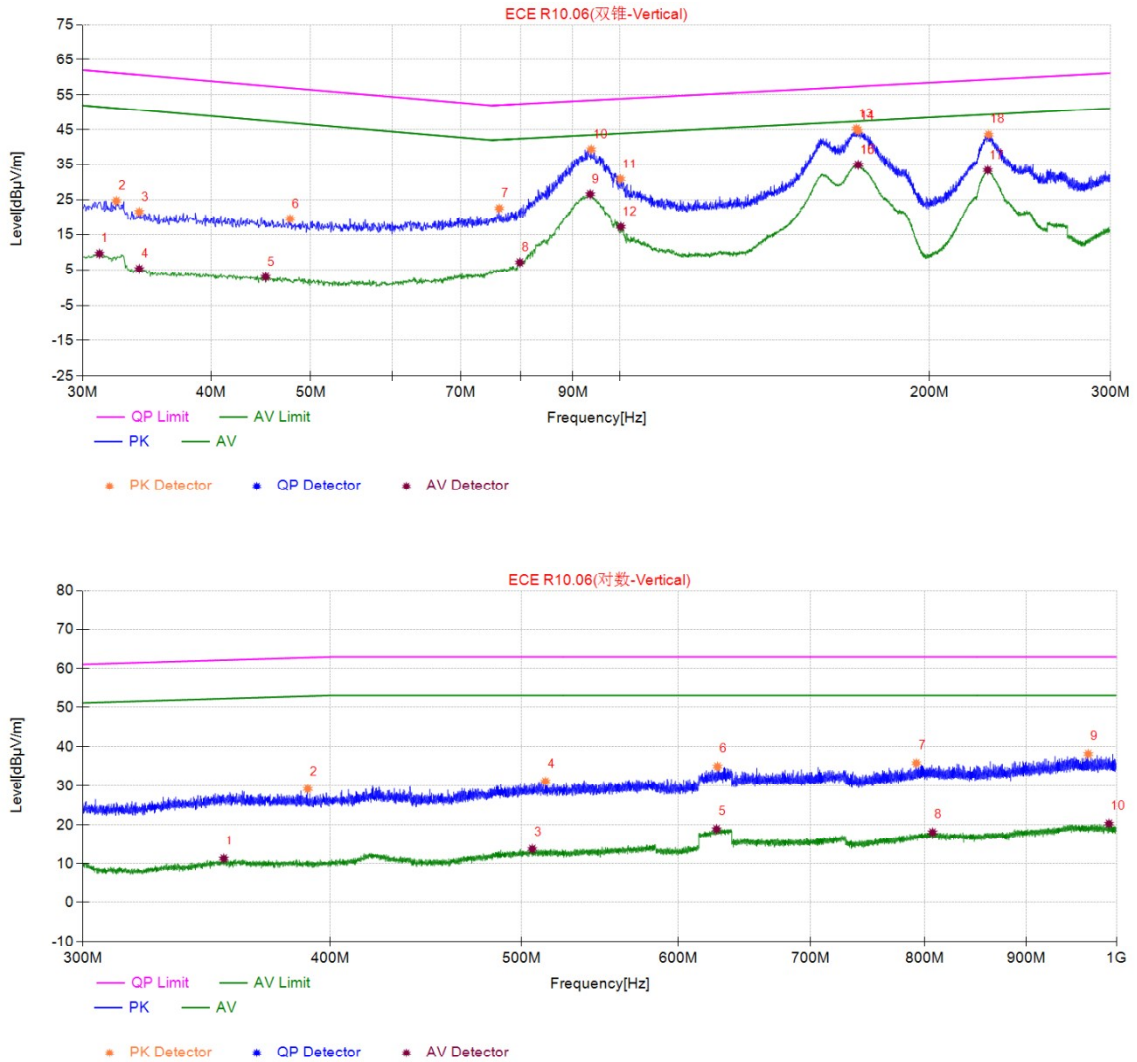

Above results show peak data and average data below the limit. The ESA is deemed to conform to the requirements in respect of this frequency band according to 6.6.2.2. of Regulation 10.06/ECE.

* LOS RESULTADOS PRESENTADOS SE REFIEREN ÚNICAMENTE A LA MUESTRA ENSAYADA.
 THE PRESENTED RESULTS REFER ONLY TO THE TESTED SAMPLE.
 * QUEDA TERMINANTEMENTE PROHIBIDA LA REPRODUCCIÓN PARCIAL DE ESTE INFORME SIN PERMISO EXPRESO DE IDIADA.
 THE PARTIAL REPRODUCTION OF THIS REPORT WITHOUT THE PERMISSION OF IDIADA IS COMPLETELY FORBIDDEN.
 * EL LABORATORIO HA CALCULADO LA INCERTIDUMBRE DE MEDIDA ASOCIADA A LOS RESULTADOS.
 MEASUREMENT UNCERTAINTY OF THE RESULTS HAS BEEN CALCULATED BY THE LABORATORY.
 * LA REGLA DE DECISIÓN UTILIZADA, SEGÚN LA NORMA ILAC-G8, HA SIDO LA DECLARACIÓN BINARIA DE ACEPTACIÓN SIMPLE.
 THE DECISION RULE USED, ACCORDING TO THE ILAC-G8 STANDARD, WAS THE BINARY STATEMENT FOR SIMPLE ACCEPTANCE

IDIADA Automotive Technology, S.A. N.I.F. A43581610 Servicio Técnico Designado de Homologación (TS)



24V Horizontal

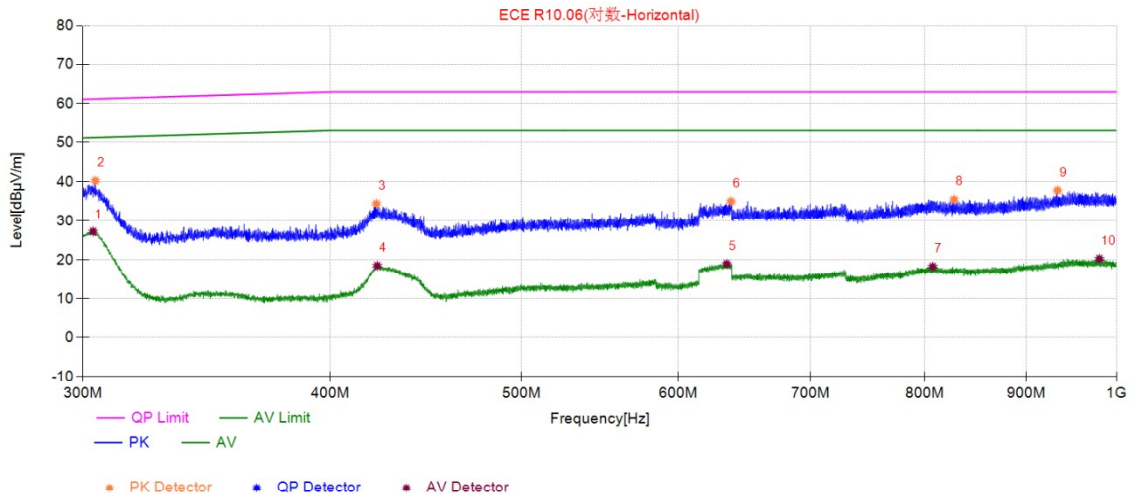
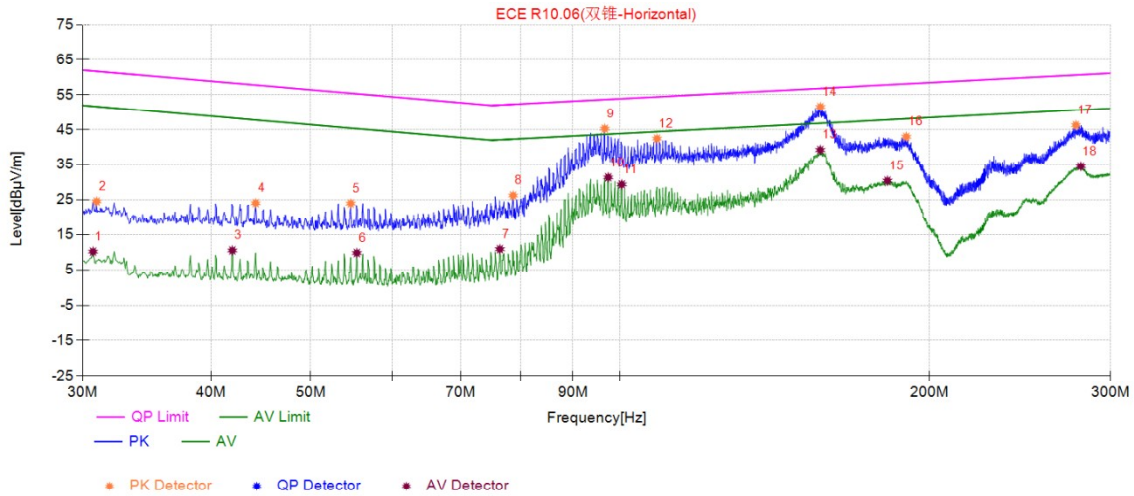

Above results show peak data and average data below the limit. The ESA is deemed to conform to the requirements in respect of this frequency band according to 6.6.2.2. of Regulation 10.06/ECE.

THE TESTS HAVE BEEN CARRIED OUT BY IDIADA AUTOMOTIVE TECHNOLOGY, S.A. (TS) LABORATORY ACCREDITED BY ENAC WITH NUMBER OF ACCREDITATION 35/LE2694
 LOS ENSAYOS HAN SIDO REALIZADOS POR IDIADA AUTOMOTIVE TECHNOLOGY, S.A. (TS) ACREDITADO POR ENAC CON NÚMERO DE ACREDITACIÓN 35/LE2694

Validate this report with the security code «1LGN2IW8» at: <https://extranet.idiada.com/hom-cve>
 Verifique el informe con código de seguridad «1LGN2IW8» en: <https://extranet.idiada.com/hom-cve>

CN23060007

IDIADA

* LOS RESULTADOS PRESENTADOS SE REFIEREN ÚNICAMENTE A LA MUESTRA ENSAYADA.
 THE PRESENTED RESULTS REFER ONLY TO THE TESTED SAMPLE.

* QUEDA TERMINANTEMENTE PROHIBIDA LA REPRODUCCIÓN PARCIAL DE ESTE INFORME SIN PERMISO EXPRESO DE IDIADA.
 THE PARTIAL REPRODUCTION OF THIS REPORT WITHOUT THE PERMISSION OF IDIADA IS COMPLETELY FORBIDDEN.

* EL LABORATORIO HA CALCULADO LA INCERTIDUMBRE DE MEDIDA ASOCIADA A LOS RESULTADOS.
 MEASUREMENT UNCERTAINTY OF THE RESULTS HAS BEEN CALCULATED BY THE LABORATORY.

* LA REGLA DE DECISIÓN UTILIZADA, SEGÚN LA NORMA ILAC-G8, HA SIDO LA DECLARACIÓN BINARIA DE ACEPTACIÓN SIMPLE
 THE DECISION RULE USED, ACCORDING TO THE ILAC-G8 STANDARD, WAS THE BINARY STATEMENT FOR SIMPLE ACCEPTANCE

IDIADA Automotive Technology, S.A. N.I.F. A43581610 Servicio Técnico Designado de Homologación (TS)



24V Vertical

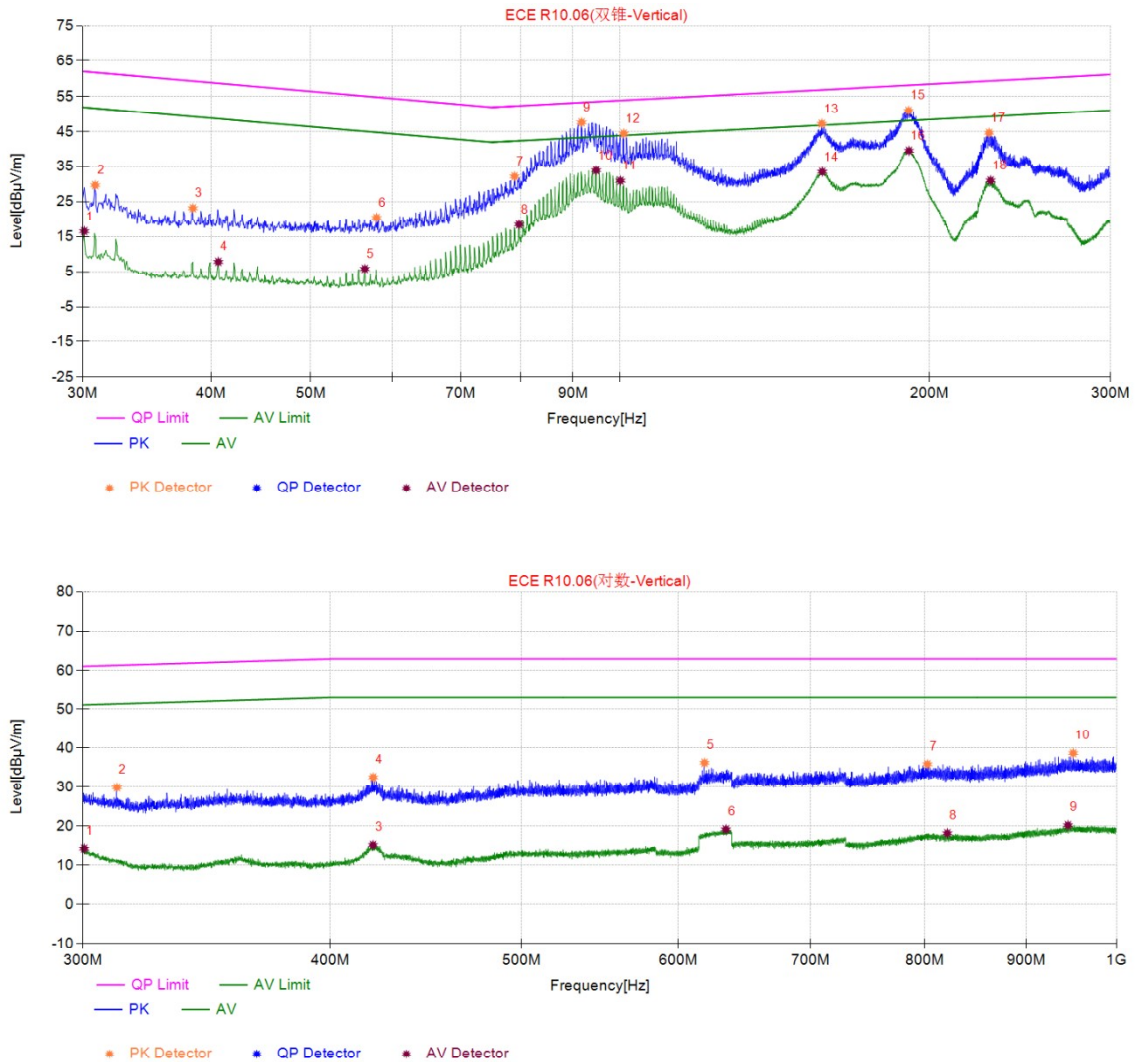

Above results show peak data and average data below the limit. The ESA is deemed to conform to the requirements in respect of this frequency band according to 6.6.2.2. of Regulation 10.06/ECE.

* LOS RESULTADOS PRESENTADOS SE REFIEREN ÚNICAMENTE A LA MUESTRA ENSAYADA.
 THE PRESENTED RESULTS REFER ONLY TO THE TESTED SAMPLE.
 * QUEDA TERMINANTEMENTE PROHIBIDA LA REPRODUCCIÓN PARCIAL DE ESTE INFORME SIN PERMISO EXPRESO DE IDIADA.
 THE PARTIAL REPRODUCTION OF THIS REPORT WITHOUT THE PERMISSION OF IDIADA IS COMPLETELY FORBIDDEN.
 * EL LABORATORIO HA CALCULADO LA INCERTIDUMBRE DE MEDIDA ASOCIADA A LOS RESULTADOS.
 MEASUREMENT UNCERTAINTY OF THE RESULTS HAS BEEN CALCULATED BY THE LABORATORY.
 * LA REGLA DE DECISIÓN UTILIZADA, SEGÚN LA NORMA ILAC-G8, HA SIDO LA DECLARACIÓN BINARIA DE ACEPTACIÓN SIMPLE
 THE DECISION RULE USED, ACCORDING TO THE ILAC-G8 STANDARD, WAS THE BINARY STATEMENT FOR SIMPLE ACCEPTANCE

IDIADA Automotive Technology, S.A. N.I.F. A43581610 Servicio Técnico Designado de Homologación (TS)



2.2. INMUNIDAD RADIADA/
RADIATED IMMUNITY

Método de ensayo/ *Test method* :

Test	Regulation	Annex
Radiated Immunity (RI)	UN REGULATION No. 10R06/02	9

Muestra de ensayo/ *Test Sample* :

Sample	Reference	Description	Sample Id. No.
#1	12V/24V	BR0103601	Q2305176-001

Equipo auxiliar/ *Auxiliary equipment* :

Sample	Reference	Description	Sample Id. No.
#1	NA	NA	NA

Condiciones ambientales/
Environmental conditions :

Temperature (°C)	Humidity (%)	Atm. Pressure (mbar)
23.8	56.2	--

Criterio de aceptación/
Acceptance criteria :

Sample	Operation Mode	Requirement	Comments
#1	OM#1	No degradation of performance of "immunity related functions".	Correct

Resultados de ensayo/ *Test results* :

Sample	Operation Mode	Method	Frequency	Severity	Modulation	Pol. / Pos.	Result
#1	OM#1	BCI	20 MHz-400 MHz	60 mA	AM 1kHz 80%	150 mm	PASS/FAIL
			400 MHz – 800 MHz		AM 1kHz 80%		Vertical (Front Harness)
		ALSE	800 MHz – 1 GHz	30 V/m	PM 217Hz 577µs	Vertical (Front EUT)	PASS/FAIL
			1 GHz – 2 GHz		PM 217Hz 577µs		PASS/FAIL

* LOS RESULTADOS PRESENTADOS SE REFIEREN ÚNICAMENTE A LA MUESTRA ENSAYADA.
THE PRESENTED RESULTS REFER ONLY TO THE TESTED SAMPLE.

* QUEDA TERMINANTEMENTE PROHIBIDA LA REPRODUCCIÓN PARCIAL DE ESTE INFORME SIN PERMISO EXPRESO DE IDIADA.
THE PARTIAL REPRODUCTION OF THIS REPORT WITHOUT THE PERMISSION OF IDIADA IS COMPLETELY FORBIDDEN.

* EL LABORATORIO HA CALCULADO LA INCERTIDUMBRE DE MEDIDA ASOCIADA A LOS RESULTADOS.
MEASUREMENT UNCERTAINTY OF THE RESULTS HAS BEEN CALCULATED BY THE LABORATORY.

* LA REGLA DE DECISIÓN UTILIZADA, SEGÚN LA NORMA ILAC-G8, HA SIDO LA DECLARACIÓN BINARIA DE ACEPTACIÓN SIMPLE
THE DECISION RULE USED, ACCORDING TO THE ILAC-G8 STANDARD, WAS THE BINARY STATEMENT FOR SIMPLE ACCEPTANCE



2.3. EMISION DE PERTURBACIONES TRANSITORIAS CONDUCCIDAS/
EMISSION OF TRANSIENT CONDUCTED DISTURBANCES

Método de ensayo/ *Test method* :

Test	Regulation	Annex
Emission of transient conducted disturbances	UN REGULATION No. 10R06/02	10

Muestra de ensayo/ *Test Sample* :

Sample	Reference	Description	Sample Id. No.
#1	12V/24V	BR0103601	Q2305176-001

Equipo auxiliar/ *Auxiliary equipment* :

Sample	Reference	Description	Sample Id. No.
#1	NA	NA	NA

Condiciones ambientales/
Environmental conditions :

Temperature (°C)	Humidity (%)	Atm. Pressure (mbar)
23.8	56.2	--

Condiciones de ensayo/
Test conditions:

Test Voltage	12V system (V)	24V system (V)
Ua	13,5 ±0,5	27 ±1
Ub	12 ±0,2	24 ±0,4

Criterio de aceptación/
Acceptance criteria :

Polarity of the pulse amplitude	Vehicles with 12 V systems	Vehicles with 24 V systems
Positive	+75 V	+150 V
Negative	-100 V	- 450 V

THE TESTS HAVE BEEN CARRIED OUT BY IDIADA AUTOMOTIVE TECHNOLOGY, S.A. (TS) LABORATORY ACCREDITED BY ENAC WITH NUMBER OF ACCREDITATION 35/LE2694
LOS ENSAYOS HAN SIDO REALIZADOS POR IDIADA AUTOMOTIVE TECHNOLOGY, S.A. (TS) ACREDITADO POR ENAC CON NÚMERO DE ACREDITACIÓN 35/LE2694

Validate this report with the security code «1LGN2IW8» at: <https://extranet.idiada.com/hom-cve>
Verifique el informe con código de seguridad «1LGN2IW8» en: <https://extranet.idiada.com/hom-cve>

IDIADA CN23060007

* LOS RESULTADOS PRESENTADOS SE REFIEREN ÚNICAMENTE A LA MUESTRA ENSAYADA.
THE PRESENTED RESULTS REFER ONLY TO THE TESTED SAMPLE.

* QUEDA TERMINANTEMENTE PROHIBIDA LA REPRODUCCIÓN PARCIAL DE ESTE INFORME SIN PERMISO EXPRESO DE IDIADA.
THE PARTIAL REPRODUCTION OF THIS REPORT WITHOUT THE PERMISSION OF IDIADA IS COMPLETELY FORBIDDEN.

* EL LABORATORIO HA CALCULADO LA INCERTIDUMBRE DE MEDIDA ASOCIADA A LOS RESULTADOS.
MEASUREMENT UNCERTAINTY OF THE RESULTS HAS BEEN CALCULATED BY THE LABORATORY.

* LA REGLA DE DECISIÓN UTILIZADA, SEGÚN LA NORMA ILAC-G8, HA SIDO LA DECLARACIÓN BINARIA DE ACEPTACIÓN SIMPLE
THE DECISION RULE USED, ACCORDING TO THE ILAC-G8 STANDARD, WAS THE BINARY STATEMENT FOR SIMPLE ACCEPTANCE



Resultados de ensayo/ Test results :

Sample	Operation Mode	Switch Configuration	Connection Disconnection Permanent	Vmax (V)	Vmin (V)	Maximum allowed pulse amplitude	Result
#1	OM#1	Slow	Switch on	20.5	0.0	+75 V -100 V	PASS/FAIL
			Switch off	13.5	0.3		PASS/FAIL
			Permanent	--	--		--
		Fast	Switch on	18.0	0.0	+75 V -100 V	PASS/FAIL
			Switch off	13.5	0.5		PASS/FAIL
			Permanent	--	--		--
		Slow	Switch on	37.0	0.0	+150 V -450 V	PASS/FAIL
			Switch off	27.0	0.0		PASS/FAIL
			Permanent	--	--		--
		Fast	Switch on	33.0	0.0	+150 V -450 V	PASS/FAIL
			Switch off	27.0	0.0		PASS/FAIL
			Permanent	--	--		--

THE TESTS HAVE BEEN CARRIED OUT BY IDIADA AUTOMOTIVE TECHNOLOGY, S.A. (TS) LABORATORY ACCREDITED BY ENAC WITH NUMBER OF ACCREDITATION 35/LE2694
 LOS ENSAYOS HAN SIDO REALIZADOS POR IDIADA AUTOMOTIVE TECHNOLOGY, S.A. (TS) ACREDITADO POR ENAC CON NÚMERO DE ACREDITACIÓN 35/LE2694

Validate this report with the security code «1LGN2IW8» at: <https://extranet.idiada.com/hom-cve>
 Verifique el informe con código de seguridad «1LGN2IW8» en: <https://extranet.idiada.com/hom-cve>

IDIADA CN23060007

* LOS RESULTADOS PRESENTADOS SE REFIEREN ÚNICAMENTE A LA MUESTRA ENSAYADA.
 THE PRESENTED RESULTS REFER ONLY TO THE TESTED SAMPLE.
 * QUEDA TERMINANTEMENTE PROHIBIDA LA REPRODUCCIÓN PARCIAL DE ESTE INFORME SIN PERMISO EXPRESO DE IDIADA.
 THE PARTIAL REPRODUCTION OF THIS REPORT WITHOUT THE PERMISSION OF IDIADA IS COMPLETELY FORBIDDEN.
 * EL LABORATORIO HA CALCULADO LA INCERTIDUMBRE DE MEDIDA ASOCIADA A LOS RESULTADOS.
 MEASUREMENT UNCERTAINTY OF THE RESULTS HAS BEEN CALCULATED BY THE LABORATORY.
 * LA REGLA DE DECISIÓN UTILIZADA, SEGÚN LA NORMA ILAC-G8, HA SIDO LA DECLARACIÓN BINARIA DE ACEPTACIÓN SIMPLE
 THE DECISION RULE USED, ACCORDING TO THE ILAC-G8 STANDARD, WAS THE BINARY STATEMENT FOR SIMPLE ACCEPTANCE



Gráficos/ Graphs :

12V Slow

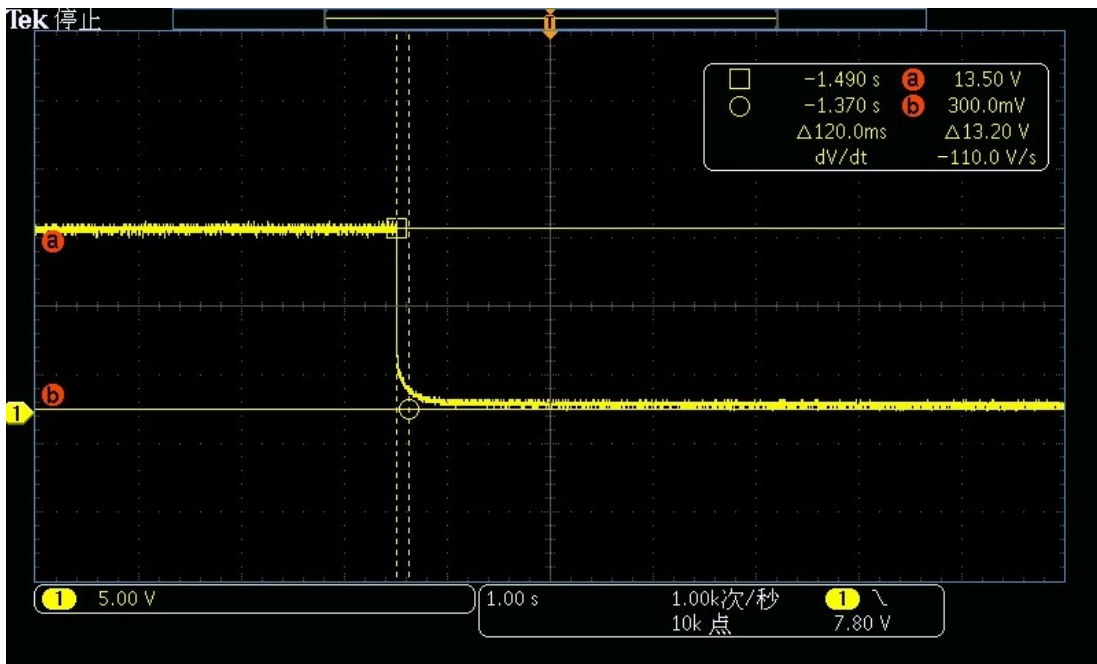
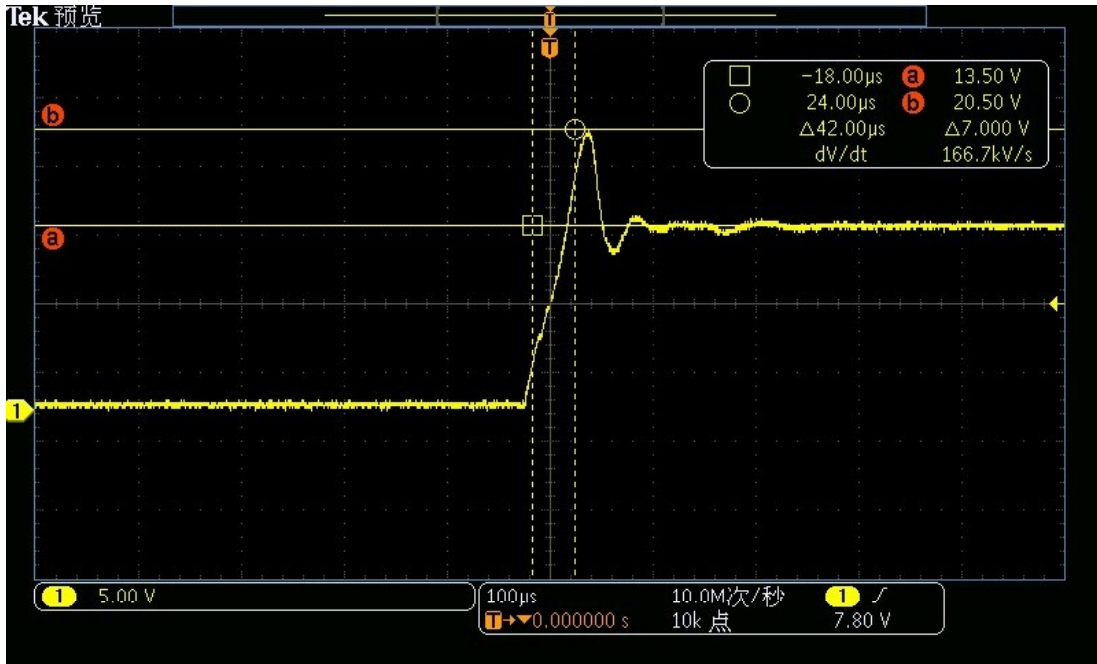

THE TESTS HAVE BEEN CARRIED OUT BY IDIADA AUTOMOTIVE TECHNOLOGY, S.A. (TS) LABORATORY ACCREDITED BY ENAC WITH NUMBER OF ACCREDITATION 35/LE2694
LOS ENSAYOS HAN SIDO REALIZADOS POR IDIADA AUTOMOTIVE TECHNOLOGY, S.A. (TS) ACREDITADO POR ENAC CON NÚMERO DE ACREDITACIÓN 35/LE2694

Validate this report with the security code «1LGN2IW8» at: <https://extranet.idiada.com/hom-cve>
Verifique el informe con código de seguridad «1LGN2IW8» en: <https://extranet.idiada.com/hom-cve>

CN23060007

IDIADA

* LOS RESULTADOS PRESENTADOS SE REFIEREN ÚNICAMENTE A LA MUESTRA ENSAYADA.
THE PRESENTED RESULTS REFER ONLY TO THE TESTED SAMPLE.

* QUEDA TERMINANTEMENTE PROHIBIDA LA REPRODUCCIÓN PARCIAL DE ESTE INFORME SIN PERMISO EXPRESO DE IDIADA.
THE PARTIAL REPRODUCTION OF THIS REPORT WITHOUT THE PERMISSION OF IDIADA IS COMPLETELY FORBIDDEN.

* EL LABORATORIO HA CALCULADO LA INCERTIDUMBRE DE MEDIDA ASOCIADA A LOS RESULTADOS.
MEASUREMENT UNCERTAINTY OF THE RESULTS HAS BEEN CALCULATED BY THE LABORATORY.

* LA REGLA DE DECISIÓN UTILIZADA, SEGÚN LA NORMA ILAC-G8, HA SIDO LA DECLARACIÓN BINARIA DE ACEPTACIÓN SIMPLE
THE DECISION RULE USED, ACCORDING TO THE ILAC-G8 STANDARD, WAS THE BINARY STATEMENT FOR SIMPLE ACCEPTANCE

IDIADA Automotive Technology, S.A. N.I.F. A43581610 Servicio Técnico Designado de Homologación (TS)



12V Fast

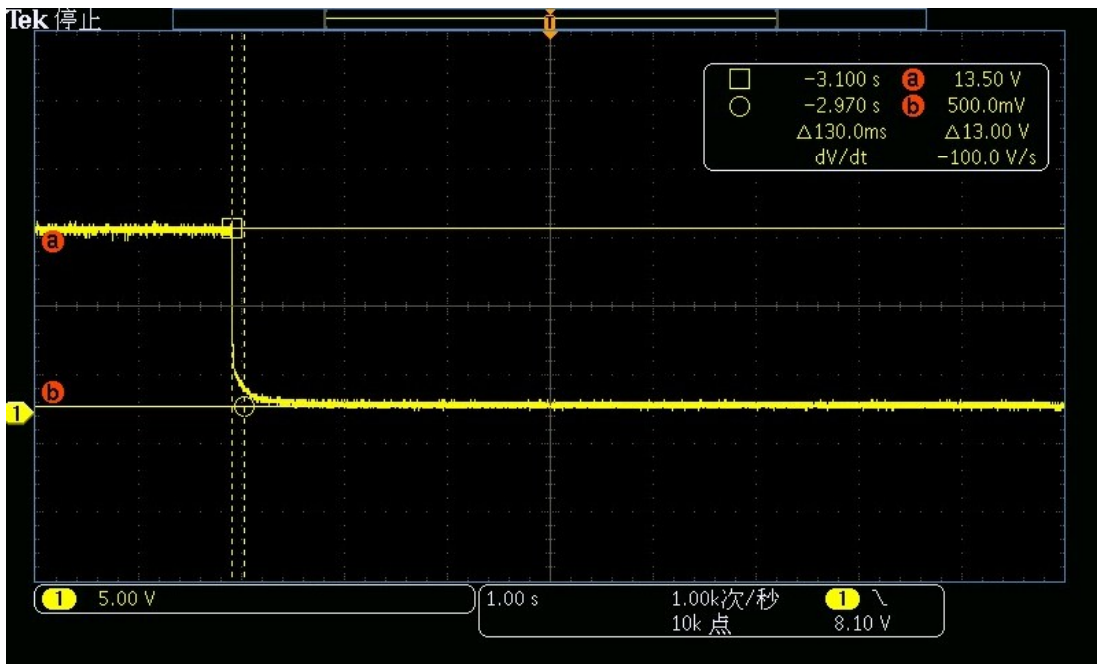
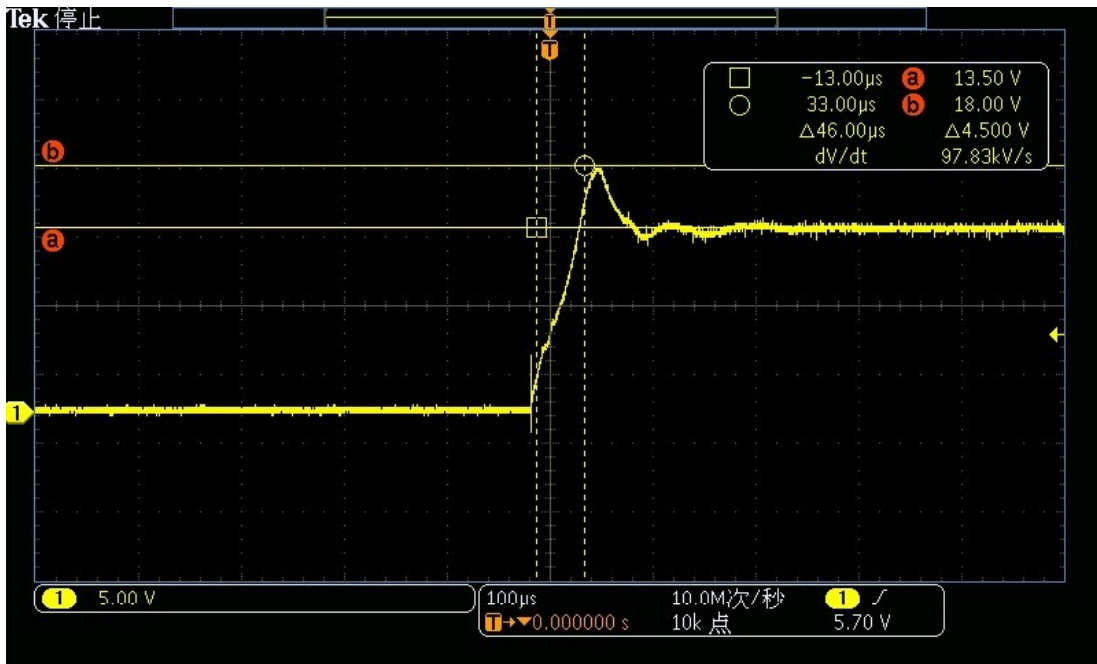

THE TESTS HAVE BEEN CARRIED OUT BY IDIADA AUTOMOTIVE TECHNOLOGY, S.A. (TS) LABORATORY ACCREDITED BY ENAC WITH NUMBER OF ACCREDITATION 35/LE2694
LOS ENSAYOS HAN SIDO REALIZADOS POR IDIADA AUTOMOTIVE TECHNOLOGY, S.A. (TS) ACREDITADO POR ENAC CON NÚMERO DE ACREDITACIÓN 35/LE2694

Validate this report with the security code «1LGN2IW8» at: <https://extranet.idiada.com/hom-cve>
Verifique el informe con código de seguridad «1LGN2IW8» en: <https://extranet.idiada.com/hom-cve>

CN23060007

* LOS RESULTADOS PRESENTADOS SE REFIEREN ÚNICAMENTE A LA MUESTRA ENSAYADA.
THE PRESENTED RESULTS REFER ONLY TO THE TESTED SAMPLE.

* QUEDA TERMINANTEMENTE PROHIBIDA LA REPRODUCCIÓN PARCIAL DE ESTE INFORME SIN PERMISO EXPRESO DE IDIADA.
THE PARTIAL REPRODUCTION OF THIS REPORT WITHOUT THE PERMISSION OF IDIADA IS COMPLETELY FORBIDDEN.

* EL LABORATORIO HA CALCULADO LA INCERTIDUMBRE DE MEDIDA ASOCIADA A LOS RESULTADOS.
MEASUREMENT UNCERTAINTY OF THE RESULTS HAS BEEN CALCULATED BY THE LABORATORY.

* LA REGLA DE DECISIÓN UTILIZADA, SEGÚN LA NORMA ILAC-G8, HA SIDO LA DECLARACIÓN BINARIA DE ACEPTACIÓN SIMPLE
THE DECISION RULE USED, ACCORDING TO THE ILAC-G8 STANDARD, WAS THE BINARY STATEMENT FOR SIMPLE ACCEPTANCE



24V Slow

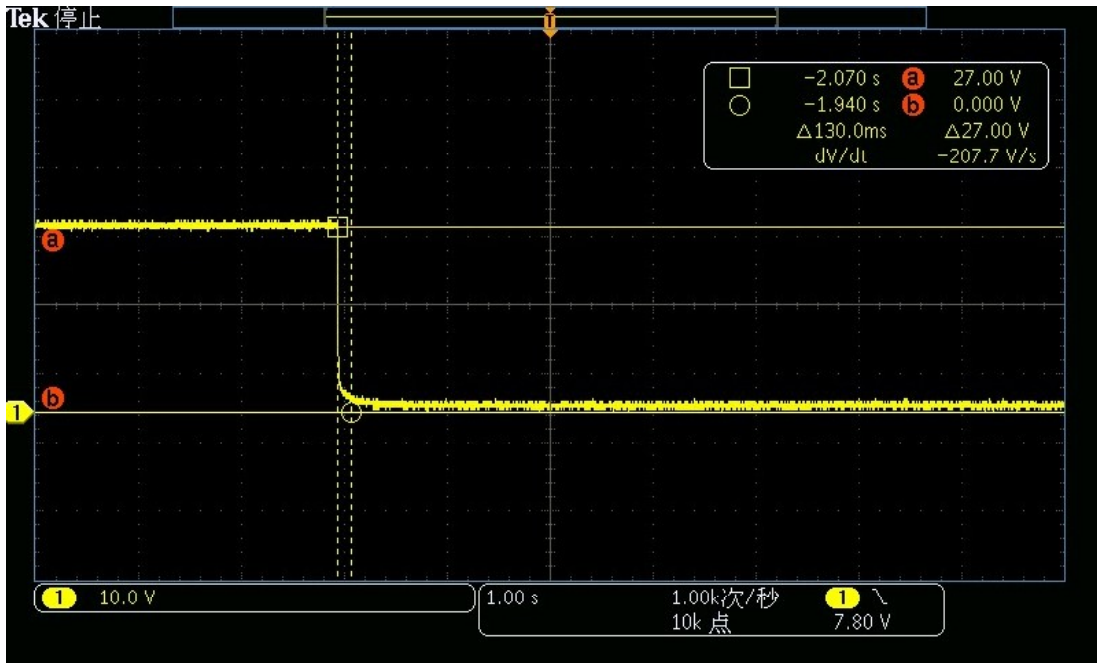
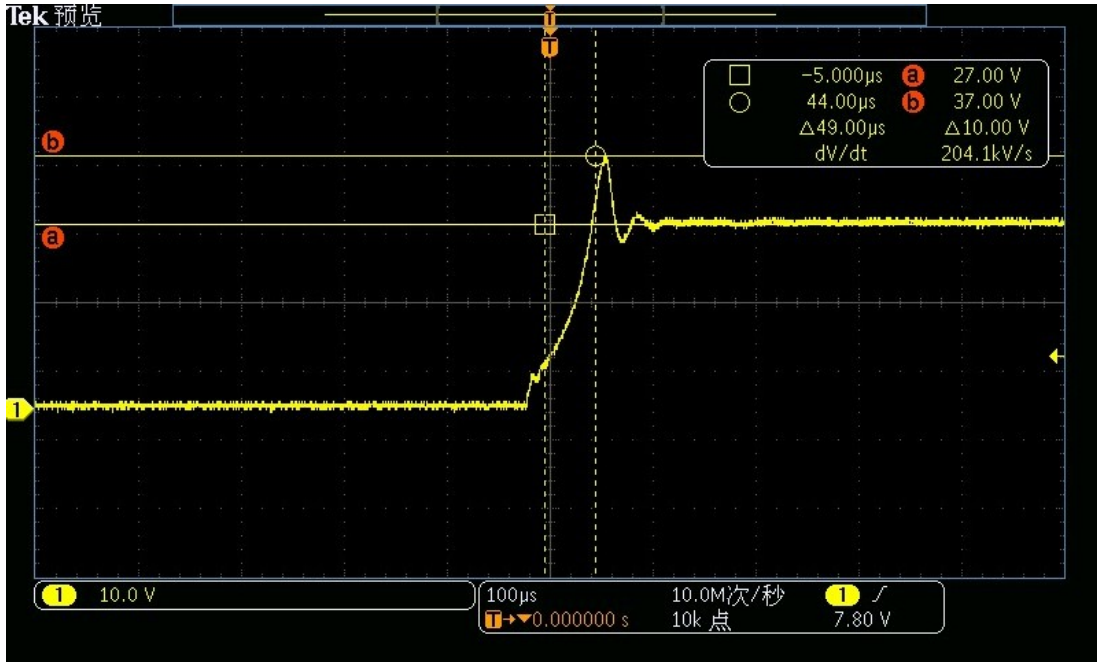

THE TESTS HAVE BEEN CARRIED OUT BY IDIADA AUTOMOTIVE TECHNOLOGY, S.A. (TS) LABORATORY ACCREDITED BY ENAC WITH NUMBER OF ACCREDITATION 35/LE2694
 LOS ENSAYOS HAN SIDO REALIZADOS POR IDIADA AUTOMOTIVE TECHNOLOGY, S.A. (TS) ACREDITADO POR ENAC CON NÚMERO DE ACREDITACIÓN 35/LE2694

Validate this report with the security code «1LGN2IW8» at: <https://extranet.idiada.com/hom-cve>
 Verifique el informe con código de seguridad «1LGN2IW8» en: <https://extranet.idiada.com/hom-cve>

CN23060007

* LOS RESULTADOS PRESENTADOS SE REFIEREN ÚNICAMENTE A LA MUESTRA ENSAYADA.
 THE PRESENTED RESULTS REFER ONLY TO THE TESTED SAMPLE.

* QUEDA TERMINANTEMENTE PROHIBIDA LA REPRODUCCIÓN PARCIAL DE ESTE INFORME SIN PERMISO EXPRESO DE IDIADA.
 THE PARTIAL REPRODUCTION OF THIS REPORT WITHOUT THE PERMISSION OF IDIADA IS COMPLETELY FORBIDDEN.

* EL LABORATORIO HA CALCULADO LA INCERTIDUMBRE DE MEDIDA ASOCIADA A LOS RESULTADOS.
 MEASUREMENT UNCERTAINTY OF THE RESULTS HAS BEEN CALCULATED BY THE LABORATORY.

* LA REGLA DE DECISIÓN UTILIZADA, SEGÚN LA NORMA ILAC-G8, HA SIDO LA DECLARACIÓN BINARIA DE ACEPTACIÓN SIMPLE
 THE DECISION RULE USED, ACCORDING TO THE ILAC-G8 STANDARD, WAS THE BINARY STATEMENT FOR SIMPLE ACCEPTANCE



24V Fast

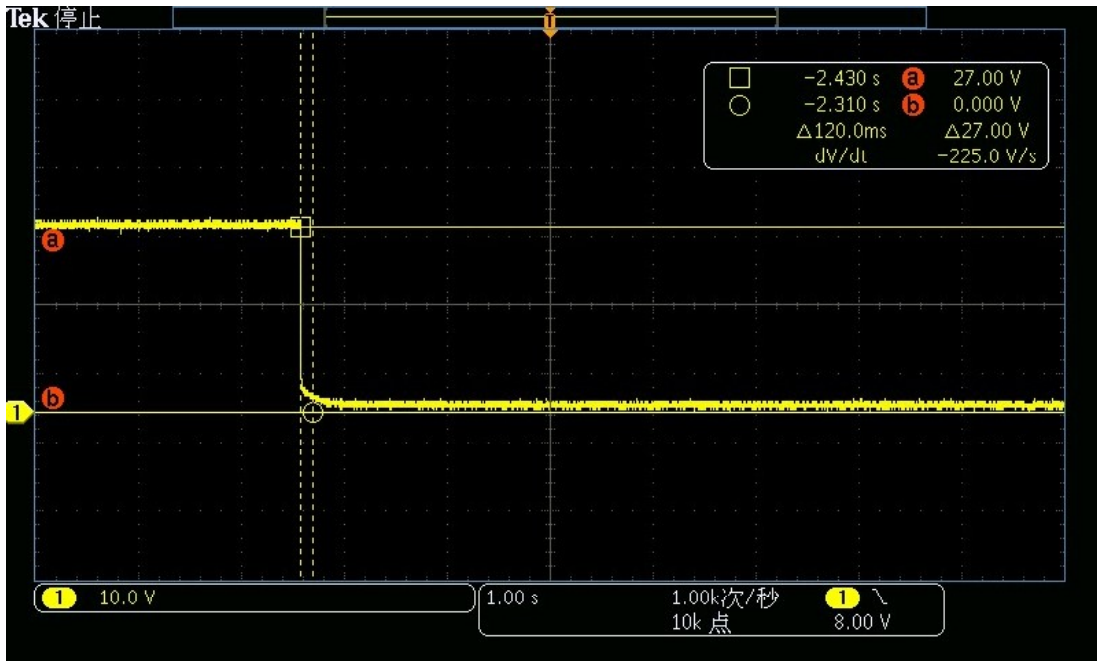
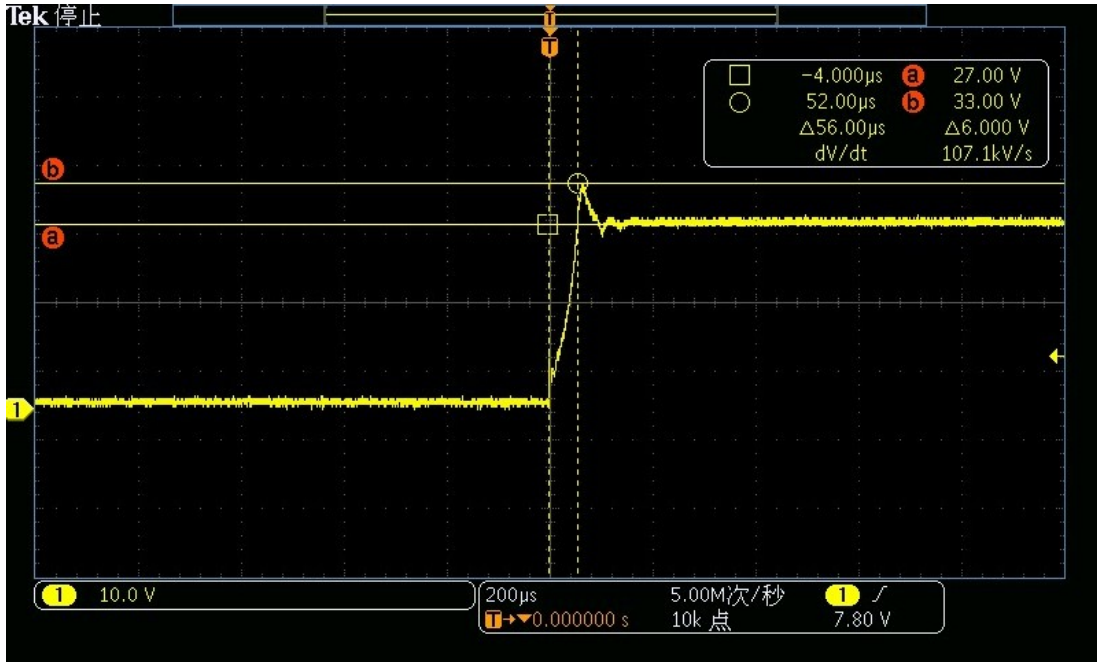

THE TESTS HAVE BEEN CARRIED OUT BY IDIADA AUTOMOTIVE TECHNOLOGY, S.A. (TS) LABORATORY ACCREDITED BY ENAC WITH NUMBER OF ACCREDITATION 35/LE2694
 LOS ENSAYOS HAN SIDO REALIZADOS POR IDIADA AUTOMOTIVE TECHNOLOGY, S.A. (TS) ACREDITADO POR ENAC CON NÚMERO DE ACREDITACIÓN 35/LE2694

Validate this report with the security code «1LGN2IW8» at: <https://extranet.idiada.com/hom-cve>
 Verifique el informe con código de seguridad «1LGN2IW8» en: <https://extranet.idiada.com/hom-cve>

CN23060007

IDIADA

* LOS RESULTADOS PRESENTADOS SE REFIEREN ÚNICAMENTE A LA MUESTRA ENSAYADA.
 THE PRESENTED RESULTS REFER ONLY TO THE TESTED SAMPLE.

* QUEDA TERMINANTEMENTE PROHIBIDA LA REPRODUCCIÓN PARCIAL DE ESTE INFORME SIN PERMISO EXPRESO DE IDIADA.
 THE PARTIAL REPRODUCTION OF THIS REPORT WITHOUT THE PERMISSION OF IDIADA IS COMPLETELY FORBIDDEN.

* EL LABORATORIO HA CALCULADO LA INCERTIDUMBRE DE MEDIDA ASOCIADA A LOS RESULTADOS.
 MEASUREMENT UNCERTAINTY OF THE RESULTS HAS BEEN CALCULATED BY THE LABORATORY.

* LA REGLA DE DECISIÓN UTILIZADA, SEGÚN LA NORMA ILAC-G8, HA SIDO LA DECLARACIÓN BINARIA DE ACEPTACIÓN SIMPLE
 THE DECISION RULE USED, ACCORDING TO THE ILAC-G8 STANDARD, WAS THE BINARY STATEMENT FOR SIMPLE ACCEPTANCE



2.4. INMUNIDAD A LAS PERTURBACIONES TRANSITORIAS CONDUcidas/
IMMUNITY TO TRANSIENT CONDUCTED DISTURBANCES

Método de ensayo/ *Test method* :

Test	Regulation	Annex
Emission of transient conducted disturbances	UN REGULATION No. 10R06/02	10

Muestra de ensayo/ *Test Sample* :

Sample	Reference	Description	Sample Id. No.
#1	12V/24V	BR0103601	Q2305176-001

Equipo auxiliar/ *Auxiliary equipment* :

Sample	Reference	Description	Sample Id. No.
#1	NA	NA	NA

Condiciones ambientales/
Environmental conditions :

Temperature (°C)	Humidity (%)	Atm. Pressure (mbar)
23.8	56.2	--

Condiciones de ensayo/
Test conditions:

Test Voltage	12V system (V)	24V system (V)
Ua	13,5 ±0,5	27 ±1
Ub	12 ±0,2	24 ±0,4

Criterio de aceptación/
Acceptance criteria :

Test pulse	Immunity level	Functional status for systems	
		Related to immunity functions	Not related to immunity functions
1	III	C	D
2a	III	B	D
2b	III	C	D
3a/3b	III	A	D
4	III	B (for ESA which must be operational during engine start phases) C (for other ESA)	D

* LOS RESULTADOS PRESENTADOS SE REFIEREN ÚNICAMENTE A LA MUESTRA ENSAYADA.
THE PRESENTED RESULTS REFER ONLY TO THE TESTED SAMPLE.

* QUEDA TERMINANTEMENTE PROHIBIDA LA REPRODUCCIÓN PARCIAL DE ESTE INFORME SIN PERMISO EXPRESO DE IDIADA.
THE PARTIAL REPRODUCTION OF THIS REPORT WITHOUT THE PERMISSION OF IDIADA IS COMPLETELY FORBIDDEN.

* EL LABORATORIO HA CALCULADO LA INCERTIDUMBRE DE MEDIDA ASOCIADA A LOS RESULTADOS.
MEASUREMENT UNCERTAINTY OF THE RESULTS HAS BEEN CALCULATED BY THE LABORATORY.

* LA REGLA DE DECISIÓN UTILIZADA, SEGÚN LA NORMA ILAC-G8, HA SIDO LA DECLARACIÓN BINARIA DE ACEPTACIÓN SIMPLE
THE DECISION RULE USED, ACCORDING TO THE ILAC-G8 STANDARD, WAS THE BINARY STATEMENT FOR SIMPLE ACCEPTANCE



Resultados de ensayo / Test results :

Sample	Operation Mode	Test pulse	Immunity level	Acceptance criteria	Result
#1	OM#1 12V	1	III	C	C
		2a	III	B	A
		2b	III	C	C
		3a/3b	III	A	A
		3b	III	A	A
		4	III	B (for ESA which must be operational during engine start phases) C (for other ESA)	B
	OM#1 24V	1	III	C	C
		2a	III	B	A
		2b	III	C	C
		3a/3b	III	A	A
		3b	III	A	A
		4	III	B (for ESA which must be operational during engine start phases) C (for other ESA)	A

THE TESTS HAVE BEEN CARRIED OUT BY IDIADA AUTOMOTIVE TECHNOLOGY, S.A. (TS) LABORATORY ACCREDITED BY ENAC WITH NUMBER OF ACCREDITATION 35/LE2694
LOS ENSAYOS HAN SIDO REALIZADOS POR IDIADA AUTOMOTIVE TECHNOLOGY, S.A. (TS) ACREDITADO POR ENAC CON NÚMERO DE ACREDITACIÓN 35/LE2694

Validate this report with the security code «1LGN2IW8» at: <https://extranet.idiada.com/hom-cve>
Verifique el informe con código de seguridad «1LGN2IW8» en: <https://extranet.idiada.com/hom-cve>

CN23060007



* LOS RESULTADOS PRESENTADOS SE REFIEREN ÚNICAMENTE A LA MUESTRA ENSAYADA.
THE PRESENTED RESULTS REFER ONLY TO THE TESTED SAMPLE.

* QUEDA TERMINANTEMENTE PROHIBIDA LA REPRODUCCIÓN PARCIAL DE ESTE INFORME SIN PERMISO EXPRESO DE IDIADA.
THE PARTIAL REPRODUCTION OF THIS REPORT WITHOUT THE PERMISSION OF IDIADA IS COMPLETELY FORBIDDEN.

* EL LABORATORIO HA CALCULADO LA INCERTIDUMBRE DE MEDIDA ASOCIADA A LOS RESULTADOS.
MEASUREMENT UNCERTAINTY OF THE RESULTS HAS BEEN CALCULATED BY THE LABORATORY.

* LA REGLA DE DECISIÓN UTILIZADA, SEGÚN LA NORMA ILAC-G8, HA SIDO LA DECLARACIÓN BINARIA DE ACEPTACIÓN SIMPLE
THE DECISION RULE USED, ACCORDING TO THE ILAC-G8 STANDARD, WAS THE BINARY STATEMENT FOR SIMPLE ACCEPTANCE



3. ENSAYOS EN LA CONFIGURACIÓN DE «MODO DE CARGA DEL REESS ACOPLADO A LA RED ELÉCTRICA»/ *TESTS IN THE CONFIGURATION “REESS CHARGING MODE COUPLED TO THE POWER GRID”*

3.1. EMISIONES RADIADAS EN MODO REES/
RADIATED EMISSIONS REES MODE

Método de ensayo/ *Test method* :

Test	Regulation	Annex
Broadband radiated emissions (BB)	UN REGULATION No. 10R06/02	7
Narrowband radiated emissions (NB)	UN REGULATION No. 10R06/02	8

Muestra de ensayo/ *Test Sample* :

Sample	Reference	Description	Sample Id. No.
NA	NA	NA	NA

Equipo auxiliar/ *Auxiliary equipment* :

Sample	Reference	Description	Sample Id. No.
NA	NA	NA	NA

Condiciones ambientales/
Environmental conditions :

Temperature (°C)	Humidity (%)	Atm. Pressure (mbar)
NA	NA	NA

Límites/ *Limits* :

Bandwidth	Broadband radiated emissions (BB)		
	Limit L (dBuV/m) in function of the frequency f (MHz)		
	Detector type: Peak		
	Frequency range		
120 kHz	30-75 MHz L=62-25.13log(f/30)	75-400 MHz L=52+15.13log(f/75)	400 MHz – 1 GHz L=63

Si se utilizan detectores de picos, se aplica un factor de corrección de 20 dB tal como se define en CISPR 12./
If peak detectors are used a correction factor of 20 dB as defined in CISPR 12 is applied.

Narrowband radiated emissions (NB) Limit (dBµV/m)		
30-75 MHz	75-400 MHz	400 MHz – 1 GHz
L=52-25.13log(f/30)	L=42+15.13log(f/75)	L=53

* LOS RESULTADOS PRESENTADOS SE REFIEREN ÚNICAMENTE A LA MUESTRA ENSAYADA.
THE PRESENTED RESULTS REFER ONLY TO THE TESTED SAMPLE.

* QUEDA TERMINANTEMENTE PROHIBIDA LA REPRODUCCIÓN PARCIAL DE ESTE INFORME SIN PERMISO EXPRESO DE IDIADA.
THE PARTIAL REPRODUCTION OF THIS REPORT WITHOUT THE PERMISSION OF IDIADA IS COMPLETELY FORBIDDEN.

* EL LABORATORIO HA CALCULADO LA INCERTIDUMBRE DE MEDIDA ASOCIADA A LOS RESULTADOS.
MEASUREMENT UNCERTAINTY OF THE RESULTS HAS BEEN CALCULATED BY THE LABORATORY.

* LA REGLA DE DECISIÓN UTILIZADA, SEGÚN LA NORMA ILAC-G8, HA SIDO LA DECLARACIÓN BINARIA DE ACEPTACIÓN SIMPLE
THE DECISION RULE USED, ACCORDING TO THE ILAC-G8 STANDARD, WAS THE BINARY STATEMENT FOR SIMPLE ACCEPTANCE



Configuración de la ESA/
ESA set up : Añadido

ESA configuration during test		
System / function	State	Comment
Charging	ON	NA
SOC	BETWEEN 20% AND 80% CHARGING CURRENT > 80% NOMINAL CURRENT	NA

Resultados de ensayo/ Test results :

Sample	Operation Mode	Frequency range	Polarization	Result
#1	OM#1	30 MHz – 200 MHz	Horizontal	PASS/FAIL
			Vertical	PASS/FAIL
		200 MHz – 1 GHz	Horizontal	PASS/FAIL
			Vertical	PASS/FAIL

Gráficos/ Graphs :

NA

THE TESTS HAVE BEEN CARRIED OUT BY IDIADA AUTOMOTIVE TECHNOLOGY, S.A. (TS) LABORATORY ACCREDITED BY ENAC WITH NUMBER OF ACCREDITATION 35/LE2694
 LOS ENSAYOS HAN SIDO REALIZADOS POR IDIADA AUTOMOTIVE TECHNOLOGY, S.A. (TS) ACREDITADO POR ENAC CON NÚMERO DE ACREDITACIÓN 35/LE2694

Validate this report with the security code «1LGN2IW8» at: <https://extranet.idiada.com/hom-cve>
 Verifique el informe con código de seguridad «1LGN2IW8» en: <https://extranet.idiada.com/hom-cve>

CN23060007



* LOS RESULTADOS PRESENTADOS SE REFIEREN ÚNICAMENTE A LA MUESTRA ENSAYADA.
THE PRESENTED RESULTS REFER ONLY TO THE TESTED SAMPLE.

* QUEDA TERMINANTEMENTE PROHIBIDA LA REPRODUCCIÓN PARCIAL DE ESTE INFORME SIN PERMISO EXPRESO DE IDIADA.
THE PARTIAL REPRODUCTION OF THIS REPORT WITHOUT THE PERMISSION OF IDIADA IS COMPLETELY FORBIDDEN.

* EL LABORATORIO HA CALCULADO LA INCERTIDUMBRE DE MEDIDA ASOCIADA A LOS RESULTADOS.
MEASUREMENT UNCERTAINTY OF THE RESULTS HAS BEEN CALCULATED BY THE LABORATORY.

* LA REGLA DE DECISIÓN UTILIZADA, SEGÚN LA NORMA ILAC-G8, HA SIDO LA DECLARACIÓN BINARIA DE ACEPTACIÓN SIMPLE
THE DECISION RULE USED, ACCORDING TO THE ILAC-G8 STANDARD, WAS THE BINARY STATEMENT FOR SIMPLE ACCEPTANCE



3.2. INMUNIDAD RADIADA EN MODO REES/
RADIATED IMMUNITY REES MODE

Método de ensayo/ *Test method* :

Test	Regulation	Annex
Radiated Immunity (RI)	UN REGULATION No. 10R06/02	9

Muestra de ensayo/ *Test Sample* :

Sample	Reference	Description	Sample Id. No.
NA	NA	NA	NA

Equipo auxiliar/ *Auxiliary equipment* :

Sample	Reference	Description	Sample Id. No.
NA	NA	NA	NA

Condiciones ambientales/
Environmental conditions :

Temperature (°C)	Humidity (%)	Atm. Pressure (mbar)
NA	NA	NA

Configuración de la ESA/
ESA set up : Añadido

ESA configuration during test		
System / function	State	Comment
Charging	ON	NA
SOC	BETWEEN 20% AND 80% CHARGING CURRENT > 80% NOMINAL CURRENT	NA

Criterio de aceptación/
Acceptance criteria : añadido

Sample	Operation Mode	Requirement	Comments
#1	OM#1	No se ven alteradas las «funciones relacionadas con la inmunidad». / <i>No degradation of performance of "immunity related functions".</i>	NA

* LOS RESULTADOS PRESENTADOS SE REFIEREN ÚNICAMENTE A LA MUESTRA ENSAYADA.
THE PRESENTED RESULTS REFER ONLY TO THE TESTED SAMPLE.

* QUEDA TERMINANTEMENTE PROHIBIDA LA REPRODUCCIÓN PARCIAL DE ESTE INFORME SIN PERMISO EXPRESO DE IDIADA.
THE PARTIAL REPRODUCTION OF THIS REPORT WITHOUT THE PERMISSION OF IDIADA IS COMPLETELY FORBIDDEN.

* EL LABORATORIO HA CALCULADO LA INCERTIDUMBRE DE MEDIDA ASOCIADA A LOS RESULTADOS.
MEASUREMENT UNCERTAINTY OF THE RESULTS HAS BEEN CALCULATED BY THE LABORATORY.

* LA REGLA DE DECISIÓN UTILIZADA, SEGÚN LA NORMA ILAC-G8, HA SIDO LA DECLARACIÓN BINARIA DE ACEPTACIÓN SIMPLE
THE DECISION RULE USED, ACCORDING TO THE ILAC-G8 STANDARD, WAS THE BINARY STATEMENT FOR SIMPLE ACCEPTANCE



Resultados de ensayo/ Test results :

Sample	Operation Mode	Method	Frequency	Severity	Modulation	Pol. / Pos.	Result
#1	OM#1	BCI	20 MHz-200 MHz	60 mA	AM 1kHz 80%	150 mm	PASS/FAIL
		ALSE	200 MHz – 800 MHz	30 V/m	AM 1kHz 80%	Vertical (Front Harness)	PASS/FAIL
			800 MHz – 1 GHz		PM 217Hz 577µs		PASS/FAIL
			1 GHz – 2 GHz		PM 217Hz 577µs	Vertical (Front EUT)	PASS/FAIL

THE TESTS HAVE BEEN CARRIED OUT BY IDIADA AUTOMOTIVE TECHNOLOGY, S.A. (TS) LABORATORY ACCREDITED BY ENAC WITH NUMBER OF ACCREDITATION 35/LE2694
 LOS ENSAYOS HAN SIDO REALIZADOS POR IDIADA AUTOMOTIVE TECHNOLOGY, S.A. (TS) ACREDITADO POR ENAC CON NÚMERO DE ACREDITACIÓN 35/LE2694

Validate this report with the security code «1LGN2IW8» at: <https://extranet.idiada.com/hom-cve>
 Verifique el informe con código de seguridad «1LGN2IW8» en: <https://extranet.idiada.com/hom-cve>

CN23060007



* LOS RESULTADOS PRESENTADOS SE REFIEREN ÚNICAMENTE A LA MUESTRA ENSAYADA.
 THE PRESENTED RESULTS REFER ONLY TO THE TESTED SAMPLE.
 * QUEDA TERMINANTEMENTE PROHIBIDA LA REPRODUCCIÓN PARCIAL DE ESTE INFORME SIN PERMISO EXPRESO DE IDIADA.
 THE PARTIAL REPRODUCTION OF THIS REPORT WITHOUT THE PERMISSION OF IDIADA IS COMPLETELY FORBIDDEN.
 * EL LABORATORIO HA CALCULADO LA INCERTIDUMBRE DE MEDIDA ASOCIADA A LOS RESULTADOS.
 MEASUREMENT UNCERTAINTY OF THE RESULTS HAS BEEN CALCULATED BY THE LABORATORY.
 * LA REGLA DE DECISIÓN UTILIZADA, SEGÚN LA NORMA ILAC-G8, HA SIDO LA DECLARACIÓN BINARIA DE ACEPTACIÓN SIMPLE
 THE DECISION RULE USED, ACCORDING TO THE ILAC-G8 STANDARD, WAS THE BINARY STATEMENT FOR SIMPLE ACCEPTANCE



3.3. EMISIONES DE HARMONICOS GENERADOS EN LINEAS AC /
EMISSION OF HARMONICS GENERATED ON AC POWER LINES

Método de ensayo/ *Test method* :

Test	Regulation	Annex
emission of harmonics generated on AC power lines from an ESA	UN REGULATION No. 10R06/02	17

Muestra de ensayo/ *Test Sample* :

Sample	Reference	Description	Sample Id. No.
NA	NA	NA	NA

Equipo auxiliar/ *Auxiliary equipment* :

Sample	Reference	Description	Sample Id. No.
NA	NA	NA	NA

Condiciones ambientales/
Environmental conditions :

Temperature (°C)	Humidity (%)	Atm. Pressure (mbar)
NA	NA	NA

Límites/ *Limits* :

Maximum allowed harmonics (input current ≤ 16 A per phase)

<i>Harmonic number</i> <i>n</i>	<i>Maximum authorized harmonic current</i> <i>A</i>
Odd harmonics	
3	2.3
5	1.14
7	0.77
9	0.40
11	0.33
13	0.21
$15 \leq n \leq 39$	$0.15 \times 15/n$
Even harmonics	
2	1.08
4	0.43
6	0.30
$8 \leq n \leq 40$	$0.23 \times 8/n$

* LOS RESULTADOS PRESENTADOS SE REFIEREN ÚNICAMENTE A LA MUESTRA ENSAYADA.
THE PRESENTED RESULTS REFER ONLY TO THE TESTED SAMPLE.

* QUEDA TERMINANTEMENTE PROHIBIDA LA REPRODUCCIÓN PARCIAL DE ESTE INFORME SIN PERMISO EXPRESO DE IDIADA.
THE PARTIAL REPRODUCTION OF THIS REPORT WITHOUT THE PERMISSION OF IDIADA IS COMPLETELY FORBIDDEN.

* EL LABORATORIO HA CALCULADO LA INCERTIDUMBRE DE MEDIDA ASOCIADA A LOS RESULTADOS.
MEASUREMENT UNCERTAINTY OF THE RESULTS HAS BEEN CALCULATED BY THE LABORATORY.

* LA REGLA DE DECISIÓN UTILIZADA, SEGÚN LA NORMA ILAC-G8, HA SIDO LA DECLARACIÓN BINARIA DE ACEPTACIÓN SIMPLE
THE DECISION RULE USED, ACCORDING TO THE ILAC-G8 STANDARD, WAS THE BINARY STATEMENT FOR SIMPLE ACCEPTANCE



Maximum allowed harmonics (input current > 16 A and ≤ 75 A per phase) for single phase or other than balanced three-phase equipment

Minimum R_{scce}	Acceptable individual harmonic current I_n/I_1 %						Maximum current harmonic ratio %	
	I_3	I_5	I_7	I_9	I_{11}	I_{13}	THD	PWHD
33	21.6	10.7	7.2	3.8	3.1	2	23	23
66	24	13	8	5	4	3	26	26
120	27	15	10	6	5	4	30	30
250	35	20	13	9	8	6	40	40
≥ 350	41	24	15	12	10	8	47	47

Maximum allowed harmonics (input current > 16 A and ≤ 75 A per phase) for balanced three-phase equipment

Minimum R_{scce}	Acceptable individual harmonic current I_n/I_1 %				Maximum current harmonic ratio %	
	I_5	I_7	I_{11}	I_{13}	THD	PWHD
33	10.7	7.2	3.1	2	13	22
66	14	9	5	3	16	25
120	19	12	7	4	22	28
250	31	20	12	7	37	38
≥ 350	40	25	15	10	48	46

Configuración de la ESA/
ESA configuration :

ESA CONFIGURATION DURING TEST		
SYSTEM / FUNCTION	STATE	COMMENT
Charging	ON	NA
SOC	BETWEEN 20% AND 80% CHARGING CURRENT > 80% NOMINAL CURRENT	NA

Resultados de ensayo / Test results :

Sample	Charging mode	Input current	Phase	Battery charge level [%]	Results
#1	(1-Phase)	≤16 A	Live	NA	PASS/FAIL
#1	(1-Phase)	≤16 A or 16 A ≤ I ≤ 75 A	Live	NA	PASS/FAIL PASS/FAIL
#1	(3-Phases)	16 A ≤ I ≤ 75 A	Live 1	NA	PASS/FAIL
			Live 2	NA	PASS/FAIL
			Live 3	NA	PASS/FAIL

* LOS RESULTADOS PRESENTADOS SE REFIEREN ÚNICAMENTE A LA MUESTRA ENSAYADA.
THE PRESENTED RESULTS REFER ONLY TO THE TESTED SAMPLE.

* QUEDA TERMINANTEMENTE PROHIBIDA LA REPRODUCCIÓN PARCIAL DE ESTE INFORME SIN PERMISO EXPRESO DE IDIADA.
THE PARTIAL REPRODUCTION OF THIS REPORT WITHOUT THE PERMISSION OF IDIADA IS COMPLETELY FORBIDDEN.

* EL LABORATORIO HA CALCULADO LA INCERTIDUMBRE DE MEDIDA ASOCIADA A LOS RESULTADOS.
MEASUREMENT UNCERTAINTY OF THE RESULTS HAS BEEN CALCULATED BY THE LABORATORY.

* LA REGLA DE DECISIÓN UTILIZADA, SEGÚN LA NORMA ILAC-G8, HA SIDO LA DECLARACIÓN BINARIA DE ACEPTACIÓN SIMPLE
THE DECISION RULE USED, ACCORDING TO THE ILAC-G8 STANDARD, WAS THE BINARY STATEMENT FOR SIMPLE ACCEPTANCE



3.4. EMISIONES DE CAMBIOS EN EL VOLTAGE, FLUCTUACIONES DE VOLTAGE Y PARPADEOS GENERADOS EN LINEAS AC / EMISSION OF VOLTAGE CHANGES, VOLTAGE FLUCTUATIONS AND FLICKER ON AC POWER LINES

Método de ensayo/ *Test method* :

Test	Regulation	Annex
emission of voltage changes, voltage fluctuations and flicker on AC power lines from an ESA	UN REGULATION No. 10R06/02	18

Muestra de ensayo/ *Test Sample* :

Sample	Reference	Description	Sample Id. No.
NA	NA	NA	NA

Equipo auxiliar/ *Auxiliary equipment* :

Sample	Reference	Description	Sample Id. No.
NA	NA	NA	NA

Condiciones ambientales/
Environmental conditions :

Temperature (°C)	Humidity (%)	Atm. Pressure (mbar)

Límites/ *Limits* :

Corriente nominal ≤ 16 A / <i>Rated current ≤ 16 A per</i>	
Criterio/Criteria	Check
El valor de Pst(short-term flicker) no deberá ser superior a 1,0 / <i>The value of Pst(short-term flicker) shall not be greater than 1.0</i>	OK/NOK
El valor de Plt(long-term flicker) no deberá ser superior a 0,65 / <i>The value of Plt (long-term flicker) shall not be greater than 0.65</i>	OK/NOK
El valor de d(t)(tiempo acumululado) durante un cambio de tensión no deberá exceder el 3,3 % durante más de 500 ms / <i>The value of d(t)(accumulated time) during a voltage change shall not exceed 3.3 per cent for more than 500 ms</i>	OK/NOK
El cambio relativo de voltaje en estado estable, dc, no debe exceder el 3,3 por ciento / <i>The relative steady state voltage change, dc, shall not exceed 3.3 per cent</i>	OK/NOK
El cambio de voltaje relativo máximo dmax, no debe exceder el 6 por ciento / <i>The maximum relative voltage change dmax, shall not exceed 6 per cent</i>	OK/NOK

* LOS RESULTADOS PRESENTADOS SE REFIEREN ÚNICAMENTE A LA MUESTRA ENSAYADA.
THE PRESENTED RESULTS REFER ONLY TO THE TESTED SAMPLE.

* QUEDA TERMINANTEMENTE PROHIBIDA LA REPRODUCCIÓN PARCIAL DE ESTE INFORME SIN PERMISO EXPRESO DE IDIADA.
THE PARTIAL REPRODUCTION OF THIS REPORT WITHOUT THE PERMISSION OF IDIADA IS COMPLETELY FORBIDDEN.

* EL LABORATORIO HA CALCULADO LA INCERTIDUMBRE DE MEDIDA ASOCIADA A LOS RESULTADOS.
MEASUREMENT UNCERTAINTY OF THE RESULTS HAS BEEN CALCULATED BY THE LABORATORY.

* LA REGLA DE DECISIÓN UTILIZADA, SEGÚN LA NORMA ILAC-G8, HA SIDO LA DECLARACIÓN BINARIA DE ACEPTACIÓN SIMPLE
THE DECISION RULE USED, ACCORDING TO THE ILAC-G8 STANDARD, WAS THE BINARY STATEMENT FOR SIMPLE ACCEPTANCE



Corriente nominal > 16 A y ≤ 75 A por fase / Rated current > 16 A and ≤ 75 A per phase	
Criterio/Criteria	Check
El valor de Pst(short-term flicker) no deberá ser superior a 1,0 / <i>The value of Pst(short-term flicker) shall not be greater than 1.0</i>	OK/NOK
El valor de Plt(long-term flicker) no deberá ser superior a 0,65 / <i>The value of Plt (long-term flicker) shall not be greater than 0.65</i>	OK/NOK
El valor de d(t)(tiempo acumululado) durante un cambio de tensión no deberá exceder el 3,3 % durante más de 500 ms / <i>The value of d(t)(accumulated time) during a voltage change shall not exceed 3.3 per cent for more than 500 ms</i>	OK/NOK
El cambio relativo de voltaje en estado estable, dc, no debe exceder el 3,3 por ciento / <i>The relative steady state voltage change, dc, shall not exceed 3.3 per cent</i>	OK/NOK
<p>El cambio de voltaje relativo máximo dmax, no debe exceder:</p> <p>1) 4 % sin condiciones adicionales; 2) 6 % para equipos que: – se activen manualmente, o – se activen automáticamente más de dos veces por día y que tengan un reinicio retardado no menor a unas décimas de segundo, o reinicio manual después de una interrupción de la fuente de alimentación</p> <p><i>/ The maximum relative voltage change dmax, shall not exceed:</i></p> <p>1) 4 % without additional conditions; 2) 6 % for equipment which is – switched manually, or – switched automatically more than twice per day and having a delayed restart (the delay being not less than a few tens of seconds), or manual restart after a power supply interruption;</p>	OK/NOK

Configuración de la ESA/
 ESA configuration :

ESA CONFIGURATION DURING TEST		
SYSTEM / FUNCTION	STATE	COMMENT
Charging	ON	NA
SOC	BETWEEN 20% AND 80% CHARGING CURRENT > 80% NOMINAL CURRENT	NA

* LOS RESULTADOS PRESENTADOS SE REFIEREN ÚNICAMENTE A LA MUESTRA ENSAYADA.
 THE PRESENTED RESULTS REFER ONLY TO THE TESTED SAMPLE.

* QUEDA TERMINANTEMENTE PROHIBIDA LA REPRODUCCIÓN PARCIAL DE ESTE INFORME SIN PERMISO EXPRESO DE IDIADA.
 THE PARTIAL REPRODUCTION OF THIS REPORT WITHOUT THE PERMISSION OF IDIADA IS COMPLETELY FORBIDDEN.

* EL LABORATORIO HA CALCULADO LA INCERTIDUMBRE DE MEDIDA ASOCIADA A LOS RESULTADOS.
 MEASUREMENT UNCERTAINTY OF THE RESULTS HAS BEEN CALCULATED BY THE LABORATORY.

* LA REGLA DE DECISIÓN UTILIZADA, SEGÚN LA NORMA ILAC-G8, HA SIDO LA DECLARACIÓN BINARIA DE ACEPTACIÓN SIMPLE
 THE DECISION RULE USED, ACCORDING TO THE ILAC-G8 STANDARD, WAS THE BINARY STATEMENT FOR SIMPLE ACCEPTANCE



Resultados de ensayo / Test results :

Sample	Charging mode	Input current	Phase	Battery charge level [%]	Results
#1	(1-Phase)	≤ 16 A	Live	NA	PASS/FAIL
#1	(1-Phase)	≤ 16 A or $16 \text{ A} \leq I \leq 75 \text{ A}$	Live	NA	PASS/FAIL
					PASS/FAIL
#1	(3-Phases)	$16 \text{ A} \leq I \leq 75 \text{ A}$	Live 1	NA	PASS/FAIL
			Live 2	NA	PASS/FAIL
			Live 3	NA	PASS/FAIL

THE TESTS HAVE BEEN CARRIED OUT BY IDIADA AUTOMOTIVE TECHNOLOGY, S.A. (TS) LABORATORY ACCREDITED BY ENAC WITH NUMBER OF ACCREDITATION 35/LE2694
 LOS ENSAYOS HAN SIDO REALIZADOS POR IDIADA AUTOMOTIVE TECHNOLOGY, S.A. (TS) ACREDITADO POR ENAC CON NÚMERO DE ACREDITACIÓN 35/LE2694

Validate this report with the security code «1LGN2IW8» at: <https://extranet.idiada.com/hom-cve>
 Verifique el informe con código de seguridad «1LGN2IW8» en: <https://extranet.idiada.com/hom-cve>

CN23060007



* LOS RESULTADOS PRESENTADOS SE REFIEREN ÚNICAMENTE A LA MUESTRA ENSAYADA.
 THE PRESENTED RESULTS REFER ONLY TO THE TESTED SAMPLE.

* QUEDA TERMINANTEMENTE PROHIBIDA LA REPRODUCCIÓN PARCIAL DE ESTE INFORME SIN PERMISO EXPRESO DE IDIADA.
 THE PARTIAL REPRODUCTION OF THIS REPORT WITHOUT THE PERMISSION OF IDIADA IS COMPLETELY FORBIDDEN.

* EL LABORATORIO HA CALCULADO LA INCERTIDUMBRE DE MEDIDA ASOCIADA A LOS RESULTADOS.
 MEASUREMENT UNCERTAINTY OF THE RESULTS HAS BEEN CALCULATED BY THE LABORATORY.

* LA REGLA DE DECISIÓN UTILIZADA, SEGÚN LA NORMA ILAC-G8, HA SIDO LA DECLARACIÓN BINARIA DE ACEPTACIÓN SIMPLE
 THE DECISION RULE USED, ACCORDING TO THE ILAC-G8 STANDARD, WAS THE BINARY STATEMENT FOR SIMPLE ACCEPTANCE



3.5. EMISIONES DE RADIOFRECUENCIAS CONDUCCIONADAS EN LINEAS AC O DC /
EMISSION OF RADIOFREQUENCY CONDUCTED DISTURBANCES ON AC OR DC
POWERLINES

Método de ensayo/ *Test method* :

Test	Regulation	Annex
emission of radiofrequency conducted disturbances on AC or DC power lines	UN REGULATION No. 10R06/02	19

Muestra de ensayo/ *Test Sample* :

Sample	Reference	Description	Sample Id. No.
NA	NA	NA	NA

Equipo auxiliar/ *Auxiliary equipment* :

Sample	Reference	Description	Sample Id. No.
NA	NA	NA	NA

Condiciones ambientales/
Environmental conditions :

Temperature (°C)	Humidity (%)	Atm. Pressure (mbar)
NA	NA	NA

Límites/ *Limits* :

Maximum allowed radiofrequency conducted disturbances on AC power lines

Frequency (MHz)	Limits and detector
0.15 to 0.5	66 to 56 dBµV (quasi-peak) 56 to 46 dBµV (average) (linearly decreasing with logarithm of frequency)
0.5 to 5	56 dBµV (quasi-peak) 46 dBµV (average)
5 to 30	60 dBµV (quasi-peak) 50 dBµV (average)

Maximum allowed radiofrequency conducted disturbances on DC power lines

Frequency (MHz)	Limits and detector
0.15 to 0.5	79 dBµV (quasi-peak) 66 dBµV (average)
0.5 to 30	73 dBµV (quasi-peak) 60 dBµV (average)

THE TESTS HAVE BEEN CARRIED OUT BY IDIADA AUTOMOTIVE TECHNOLOGY, S.A. (TS) LABORATORY ACCREDITED BY ENAC WITH NUMBER OF ACCREDITATION 35/LE2694
 LOS ENSAYOS HAN SIDO REALIZADOS POR IDIADA AUTOMOTIVE TECHNOLOGY, S.A. (TS) ACREDITADO POR ENAC CON NÚMERO DE ACREDITACIÓN 35/LE2694

Validate this report with the security code «1LGN2IW8» at: <https://extranet.idiada.com/hom-cve>
 Verifique el informe con código de seguridad «1LGN2IW8» en: <https://extranet.idiada.com/hom-cve>

IDIADA CN23060007

* LOS RESULTADOS PRESENTADOS SE REFIEREN ÚNICAMENTE A LA MUESTRA ENSAYADA.
 THE PRESENTED RESULTS REFER ONLY TO THE TESTED SAMPLE.

* QUEDA TERMINANTEMENTE PROHIBIDA LA REPRODUCCIÓN PARCIAL DE ESTE INFORME SIN PERMISO EXPRESO DE IDIADA.
 THE PARTIAL REPRODUCTION OF THIS REPORT WITHOUT THE PERMISSION OF IDIADA IS COMPLETELY FORBIDDEN.

* EL LABORATORIO HA CALCULADO LA INCERTIDUMBRE DE MEDIDA ASOCIADA A LOS RESULTADOS.
 MEASUREMENT UNCERTAINTY OF THE RESULTS HAS BEEN CALCULATED BY THE LABORATORY.

* LA REGLA DE DECISIÓN UTILIZADA, SEGÚN LA NORMA ILAC-G8, HA SIDO LA DECLARACIÓN BINARIA DE ACEPTACIÓN SIMPLE
 THE DECISION RULE USED, ACCORDING TO THE ILAC-G8 STANDARD, WAS THE BINARY STATEMENT FOR SIMPLE ACCEPTANCE



Configuración de la ESA/
ESA configuration

:

ESA CONFIGURATION DURING TEST		
SYSTEM / FUNCTION	STATE	COMMENT
Charging	ON	NA
SOC	BETWEEN 20% AND 80% CHARGING CURRENT > 80% NOMINAL CURRENT	NA

Resultados de ensayo / Test results :

Sample	Charging mode	Input current	Phase	Battery charge level [%]	Results
#1	(1-Phase)	≤ 16 A	Live	NA	PASS/FAIL
#1	(1-Phase)	≤ 16 A or 16 A $\leq I \leq 75$ A	Live	NA	PASS/FAIL
					PASS/FAIL
#1	(3-Phases)	16 A $\leq I \leq 75$ A	Live 1	NA	PASS/FAIL
			Live 2	NA	PASS/FAIL
			Live 3	NA	PASS/FAIL

* LOS RESULTADOS PRESENTADOS SE REFIEREN ÚNICAMENTE A LA MUESTRA ENSAYADA.
THE PRESENTED RESULTS REFER ONLY TO THE TESTED SAMPLE.

* QUEDA TERMINANTEMENTE PROHIBIDA LA REPRODUCCIÓN PARCIAL DE ESTE INFORME SIN PERMISO EXPRESO DE IDIADA.
THE PARTIAL REPRODUCTION OF THIS REPORT WITHOUT THE PERMISSION OF IDIADA IS COMPLETELY FORBIDDEN.

* EL LABORATORIO HA CALCULADO LA INCERTIDUMBRE DE MEDIDA ASOCIADA A LOS RESULTADOS.
MEASUREMENT UNCERTAINTY OF THE RESULTS HAS BEEN CALCULATED BY THE LABORATORY.

* LA REGLA DE DECISIÓN UTILIZADA, SEGÚN LA NORMA ILAC-G8, HA SIDO LA DECLARACIÓN BINARIA DE ACEPTACIÓN SIMPLE
THE DECISION RULE USED, ACCORDING TO THE ILAC-G8 STANDARD, WAS THE BINARY STATEMENT FOR SIMPLE ACCEPTANCE



3.6. EMISIONES DE RADIOFRECUENCIAS DE PERTURBACIONES CONDUCCION EN PUERTOS DE REDES CABLEADAS / EMISSION OF RADIOFREQUENCY CONDUCTED DISTURBANCES ON WIRED NETWORK PORT

Método de ensayo/ *Test method* :

Test	Regulation	Annex
Emission of radiofrequency conducted disturbances on wired network port	UN REGULATION No. 10R06/02	20

Muestra de ensayo/ *Test Sample* :

Sample	Reference	Description	Sample Id. No.
NA	NA	NA	NA

Equipo auxiliar/ *Auxiliary equipment* :

Sample	Reference	Description	Sample Id. No.
NA	NA	NA	NA

Condiciones ambientales/
Environmental conditions :

Temperature (°C)	Humidity (%)	Atm. Pressure (mbar)
NA	NA	NA

Límites/ *Limits* :

Maximum allowed radiofrequency conducted disturbances on wired network port

Frequency (MHz)	Voltage limits (detector)	Current limits (detector)
0.15 to 0.5	84 to 74 dBµV (quasi-peak) 74 to 64 dBµV (average) (linearly decreasing with logarithm of frequency)	40 to 30 dBµA (quasi-peak) 30 to 20 dBµA (average) (linearly decreasing with logarithm of frequency)
0.5 to 30	74 dBµV (quasi-peak) 64 dBµV (average)	30 dBµA (quasi-peak) 20 dBµA (average)

Configuración de la ESA/
ESA configuration :

ESA CONFIGURATION DURING TEST		
SYSTEM / FUNCTION	STATE	COMMENT
Charging	ON	NA
SOC	BETWEEN 20% AND 80% CHARGING CURRENT > 80% NOMINAL CURRENT	NA

* LOS RESULTADOS PRESENTADOS SE REFIEREN ÚNICAMENTE A LA MUESTRA ENSAYADA.
THE PRESENTED RESULTS REFER ONLY TO THE TESTED SAMPLE.

* QUEDA TERMINANTEMENTE PROHIBIDA LA REPRODUCCIÓN PARCIAL DE ESTE INFORME SIN PERMISO EXPRESO DE IDIADA.
THE PARTIAL REPRODUCTION OF THIS REPORT WITHOUT THE PERMISSION OF IDIADA IS COMPLETELY FORBIDDEN.

* EL LABORATORIO HA CALCULADO LA INCERTIDUMBRE DE MEDIDA ASOCIADA A LOS RESULTADOS.
MEASUREMENT UNCERTAINTY OF THE RESULTS HAS BEEN CALCULATED BY THE LABORATORY.

* LA REGLA DE DECISIÓN UTILIZADA, SEGÚN LA NORMA ILAC-G8, HA SIDO LA DECLARACIÓN BINARIA DE ACEPTACIÓN SIMPLE
THE DECISION RULE USED, ACCORDING TO THE ILAC-G8 STANDARD, WAS THE BINARY STATEMENT FOR SIMPLE ACCEPTANCE



Resultados de ensayo / Test results :

Sample	Charging mode	Input current	Phase	Battery charge level [%]	Results
#1	(1-Phase)	≤ 16 A	Live	NA	PASS/FAIL
#1	(1-Phase)	≤ 16 A or $16 \text{ A} \leq I \leq 75 \text{ A}$	Live	NA	PASS/FAIL
					PASS/FAIL
#1	(3-Phases)	$16 \text{ A} \leq I \leq 75 \text{ A}$	Live 1	NA	PASS/FAIL
			Live 2	NA	PASS/FAIL
			Live 3	NA	PASS/FAIL

THE TESTS HAVE BEEN CARRIED OUT BY IDIADA AUTOMOTIVE TECHNOLOGY, S.A. (TS) LABORATORY ACCREDITED BY ENAC WITH NUMBER OF ACCREDITATION 35/LE2694
 LOS ENSAYOS HAN SIDO REALIZADOS POR IDIADA AUTOMOTIVE TECHNOLOGY, S.A. (TS) ACREDITADO POR ENAC CON NÚMERO DE ACREDITACIÓN 35/LE2694

Validate this report with the security code «1LGN2IW8» at: <https://extranet.idiada.com/hom-cve>
 Verifique el informe con código de seguridad «1LGN2IW8» en: <https://extranet.idiada.com/hom-cve>

CN23060007



* LOS RESULTADOS PRESENTADOS SE REFIEREN ÚNICAMENTE A LA MUESTRA ENSAYADA.
 THE PRESENTED RESULTS REFER ONLY TO THE TESTED SAMPLE.

* QUEDA TERMINANTEMENTE PROHIBIDA LA REPRODUCCIÓN PARCIAL DE ESTE INFORME SIN PERMISO EXPRESO DE IDIADA.
 THE PARTIAL REPRODUCTION OF THIS REPORT WITHOUT THE PERMISSION OF IDIADA IS COMPLETELY FORBIDDEN.

* EL LABORATORIO HA CALCULADO LA INCERTIDUMBRE DE MEDIDA ASOCIADA A LOS RESULTADOS.
 MEASUREMENT UNCERTAINTY OF THE RESULTS HAS BEEN CALCULATED BY THE LABORATORY.

* LA REGLA DE DECISIÓN UTILIZADA, SEGÚN LA NORMA ILAC-G8, HA SIDO LA DECLARACIÓN BINARIA DE ACEPTACIÓN SIMPLE
 THE DECISION RULE USED, ACCORDING TO THE ILAC-G8 STANDARD, WAS THE BINARY STATEMENT FOR SIMPLE ACCEPTANCE



3.7. IMMUNIDAD A LAS PERTURBACIONES ELÉCTRICAS RÁPIDAS TRANSITORIAS O RÁFAGAS CONDUCIDAS POR LAS LÍNEAS DE ALIMENTACIÓN DE CORRIENTE ALTERNA O CORRIENTE CONTÍNUA / IMMUNITY TO ELECTRICAL FAST TRANSIENT/BURST DISTURBANCES CONDUCTED ALONG AC AND DC POWER LINES

Método de ensayo/ *Test method* :

Test	Regulation	Annex
Immunity to electrical fast transient/burst disturbances conducted along AC and DC power lines	UN REGULATION No. 10R06/02	21

Muestra de ensayo/ *Test Sample* :

Sample	Reference	Description	Sample Id. No.
NA	NA	NA	NA

Equipo auxiliar/ *Auxiliary equipment* :

Sample	Reference	Description	Sample Id. No.
NA	NA	NA	NA

Condiciones ambientales/
Environmental conditions :

Temperature (°C)	Humidity (%)	Atm. Pressure (mbar)
NA	NA	NA

Configuración de la ESA/
ESA configuration :

ESA CONFIGURATION DURING TEST		
SYSTEM / FUNCTION	STATE	COMMENT
Charging	ON	NA
SOC	BETWEEN 20% AND 80% CHARGING CURRENT > 80% NOMINAL CURRENT	NA

Criterio de fallo/
Failure criterio: :

- Condición incorrecta en la carga (ej. Sobre-corriente, sobrevoltaje) / *Incorrect charging condition (e.g. over-current, overvoltage)*

* LOS RESULTADOS PRESENTADOS SE REFIEREN ÚNICAMENTE A LA MUESTRA ENSAYADA.
THE PRESENTED RESULTS REFER ONLY TO THE TESTED SAMPLE.

* QUEDA TERMINANTEMENTE PROHIBIDA LA REPRODUCCIÓN PARCIAL DE ESTE INFORME SIN PERMISO EXPRESO DE IDIADA.
THE PARTIAL REPRODUCTION OF THIS REPORT WITHOUT THE PERMISSION OF IDIADA IS COMPLETELY FORBIDDEN.

* EL LABORATORIO HA CALCULADO LA INCERTIDUMBRE DE MEDIDA ASOCIADA A LOS RESULTADOS.
MEASUREMENT UNCERTAINTY OF THE RESULTS HAS BEEN CALCULATED BY THE LABORATORY.

* LA REGLA DE DECISIÓN UTILIZADA, SEGÚN LA NORMA ILAC-G8, HA SIDO LA DECLARACIÓN BINARIA DE ACEPTACIÓN SIMPLE
THE DECISION RULE USED, ACCORDING TO THE ILAC-G8 STANDARD, WAS THE BINARY STATEMENT FOR SIMPLE ACCEPTANCE

IDIADA Automotive Technology, S.A. N.I.F. A43581610 Servicio Técnico Designado de Homologación (TS)



Resultados de ensayo / Test results :

Sample	Charging mode	Input current	Phase	Battery charge level [%]	Results
#1	(1-Phase)	≤ 16 A	Live	NA	PASS/FAIL
#1	(1-Phase)	≤ 16 A or $16 \text{ A} \leq I \leq 75 \text{ A}$	Live	NA	PASS/FAIL
					PASS/FAIL
#1	(3-Phases)	$16 \text{ A} \leq I \leq 75 \text{ A}$	Live 1	NA	PASS/FAIL
			Live 2	NA	PASS/FAIL
			Live 3	NA	PASS/FAIL

THE TESTS HAVE BEEN CARRIED OUT BY IDIADA AUTOMOTIVE TECHNOLOGY, S.A. (TS) LABORATORY ACCREDITED BY ENAC WITH NUMBER OF ACCREDITATION 35/LE2694
 LOS ENSAYOS HAN SIDO REALIZADOS POR IDIADA AUTOMOTIVE TECHNOLOGY, S.A. (TS) ACREDITADO POR ENAC CON NÚMERO DE ACREDITACIÓN 35/LE2694

Validate this report with the security code «1LGN2IW8» at: <https://extranet.idiada.com/hom-cve>
 Verifique el informe con código de seguridad «1LGN2IW8» en: <https://extranet.idiada.com/hom-cve>

CN23060007

* LOS RESULTADOS PRESENTADOS SE REFIEREN ÚNICAMENTE A LA MUESTRA ENSAYADA.
 THE PRESENTED RESULTS REFER ONLY TO THE TESTED SAMPLE.

* QUEDA TERMINANTEMENTE PROHIBIDA LA REPRODUCCIÓN PARCIAL DE ESTE INFORME SIN PERMISO EXPRESO DE IDIADA.
 THE PARTIAL REPRODUCTION OF THIS REPORT WITHOUT THE PERMISSION OF IDIADA IS COMPLETELY FORBIDDEN.

* EL LABORATORIO HA CALCULADO LA INCERTIDUMBRE DE MEDIDA ASOCIADA A LOS RESULTADOS.
 MEASUREMENT UNCERTAINTY OF THE RESULTS HAS BEEN CALCULATED BY THE LABORATORY.

* LA REGLA DE DECISIÓN UTILIZADA, SEGÚN LA NORMA ILAC-G8, HA SIDO LA DECLARACIÓN BINARIA DE ACEPTACIÓN SIMPLE
 THE DECISION RULE USED, ACCORDING TO THE ILAC-G8 STANDARD, WAS THE BINARY STATEMENT FOR SIMPLE ACCEPTANCE



3.8. IMMUNIDAD A LAS SOBRETENSIONES ELÉCTRICAS CONDUCCIDAS POR LAS LÍNEAS DE ALIMENTACIÓN DE CORRIENTE ALTERNA O CORRIENTE CONTÍNUA / IMMUNITY TO SURGES CONDUCTED ALONG AC AND DC POWER LINES

Método de ensayo/ *Test method* :

Test	Regulation	Annex
Immunity to surges conducted along AC and DC power lines	UN REGULATION No. 10R06/02	22

Muestra de ensayo/ *Test Sample* :

Sample	Reference	Description	Sample Id. No.
NA	NA	NA	NA

Equipo auxiliar/ *Auxiliary equipment* :

Sample	Reference	Description	Sample Id. No.
NA	NA	NA	NA

Condiciones ambientales/
Environmental conditions :

Temperature (°C)	Humidity (%)	Atm. Pressure (mbar)
NA	NA	NA

Configuración de la ESA/
ESA configuration :

ESA CONFIGURATION DURING TEST		
SYSTEM / FUNCTION	STATE	COMMENT
Charging	ON	NA
SOC	BETWEEN 20% AND 80% CHARGING CURRENT > 80% NOMINAL CURRENT	NA

* LOS RESULTADOS PRESENTADOS SE REFIEREN ÚNICAMENTE A LA MUESTRA ENSAYADA.
THE PRESENTED RESULTS REFER ONLY TO THE TESTED SAMPLE.

* QUEDA TERMINANTEMENTE PROHIBIDA LA REPRODUCCIÓN PARCIAL DE ESTE INFORME SIN PERMISO EXPRESO DE IDIADA.
THE PARTIAL REPRODUCTION OF THIS REPORT WITHOUT THE PERMISSION OF IDIADA IS COMPLETELY FORBIDDEN.

* EL LABORATORIO HA CALCULADO LA INCERTIDUMBRE DE MEDIDA ASOCIADA A LOS RESULTADOS.
MEASUREMENT UNCERTAINTY OF THE RESULTS HAS BEEN CALCULATED BY THE LABORATORY.

* LA REGLA DE DECISIÓN UTILIZADA, SEGÚN LA NORMA ILAC-G8, HA SIDO LA DECLARACIÓN BINARIA DE ACEPTACIÓN SIMPLE
THE DECISION RULE USED, ACCORDING TO THE ILAC-G8 STANDARD, WAS THE BINARY STATEMENT FOR SIMPLE ACCEPTANCE

IDIADA Automotive Technology, S.A. N.I.F. A43581610 Servicio Técnico Designado de Homologación (TS)



Criterio de fallo/
Failure criterion:

- Condición incorrecta en la carga (ej. Sobre-corriente, sobrevoltaje) / *Incorrect charging condition (e.g. over-current, overvoltage)*

Resultados de ensayo / Test results :

Sample	Charging mode	Input current	Phase	Battery charge level [%]	Results
#1	(1-Phase)	≤ 16 A	Live	NA	PASS/FAIL
#1	(1-Phase)	≤ 16 A or 16 A $\leq I \leq 75$ A	Live	NA	PASS/FAIL
					PASS/FAIL
#1	(3-Phases)	16 A $\leq I \leq 75$ A	Live 1	NA	PASS/FAIL
			Live 2	NA	PASS/FAIL
			Live 3	NA	PASS/FAIL

* LOS RESULTADOS PRESENTADOS SE REFIEREN ÚNICAMENTE A LA MUESTRA ENSAYADA.
THE PRESENTED RESULTS REFER ONLY TO THE TESTED SAMPLE.

* QUEDA TERMINANTEMENTE PROHIBIDA LA REPRODUCCIÓN PARCIAL DE ESTE INFORME SIN PERMISO EXPRESO DE IDIADA.
THE PARTIAL REPRODUCTION OF THIS REPORT WITHOUT THE PERMISSION OF IDIADA IS COMPLETELY FORBIDDEN.

* EL LABORATORIO HA CALCULADO LA INCERTIDUMBRE DE MEDIDA ASOCIADA A LOS RESULTADOS.
MEASUREMENT UNCERTAINTY OF THE RESULTS HAS BEEN CALCULATED BY THE LABORATORY.

* LA REGLA DE DECISIÓN UTILIZADA, SEGÚN LA NORMA ILAC-G8, HA SIDO LA DECLARACIÓN BINARIA DE ACEPTACIÓN SIMPLE
THE DECISION RULE USED, ACCORDING TO THE ILAC-G8 STANDARD, WAS THE BINARY STATEMENT FOR SIMPLE ACCEPTANCE



4. FOTOGRAFÍAS/ PICTURES

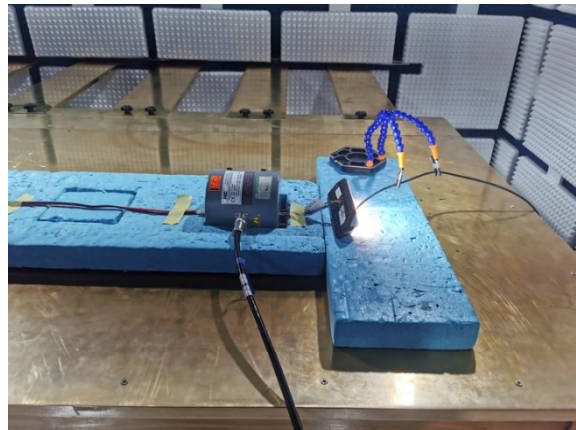
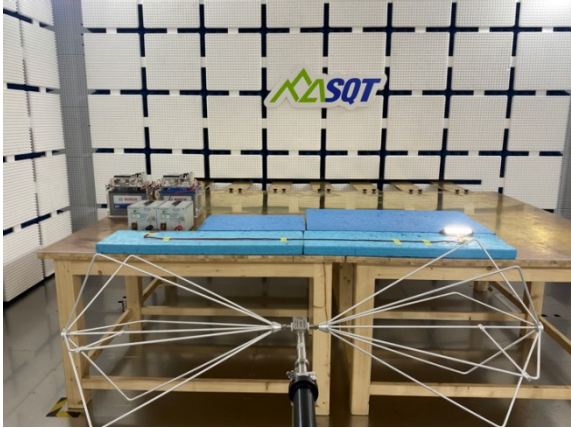

THE TESTS HAVE BEEN CARRIED OUT BY IDIADA AUTOMOTIVE TECHNOLOGY, S.A. (TS) LABORATORY ACCREDITED BY ENAC WITH NUMBER OF ACCREDITATION 35/LE2694
LOS ENSAYOS HAN SIDO REALIZADOS POR IDIADA AUTOMOTIVE TECHNOLOGY, S.A. (TS) ACREDITADO POR ENAC CON NÚMERO DE ACREDITACIÓN 35/LE2694

Validate this report with the security code «1LGN2IW8» at: <https://extranet.idiada.com/hom-cve>
Verifique el informe con código de seguridad «1LGN2IW8» en: <https://extranet.idiada.com/hom-cve>

CN23060007

* LOS RESULTADOS PRESENTADOS SE REFIEREN ÚNICAMENTE A LA MUESTRA ENSAYADA.
THE PRESENTED RESULTS REFER ONLY TO THE TESTED SAMPLE.

* QUEDA TERMINANTEMENTE PROHIBIDA LA REPRODUCCIÓN PARCIAL DE ESTE INFORME SIN PERMISO EXPRESO DE IDIADA.
THE PARTIAL REPRODUCTION OF THIS REPORT WITHOUT THE PERMISSION OF IDIADA IS COMPLETELY FORBIDDEN.

* EL LABORATORIO HA CALCULADO LA INCERTIDUMBRE DE MEDIDA ASOCIADA A LOS RESULTADOS.
MEASUREMENT UNCERTAINTY OF THE RESULTS HAS BEEN CALCULATED BY THE LABORATORY.

* LA REGLA DE DECISIÓN UTILIZADA, SEGÚN LA NORMA ILAC-G8, HA SIDO LA DECLARACIÓN BINARIA DE ACEPTACIÓN SIMPLE
THE DECISION RULE USED, ACCORDING TO THE ILAC-G8 STANDARD, WAS THE BINARY STATEMENT FOR SIMPLE ACCEPTANCE

IDIADA Automotive Technology, S.A. N.I.F. A43581610 Servicio Técnico Designado de Homologación (TS)

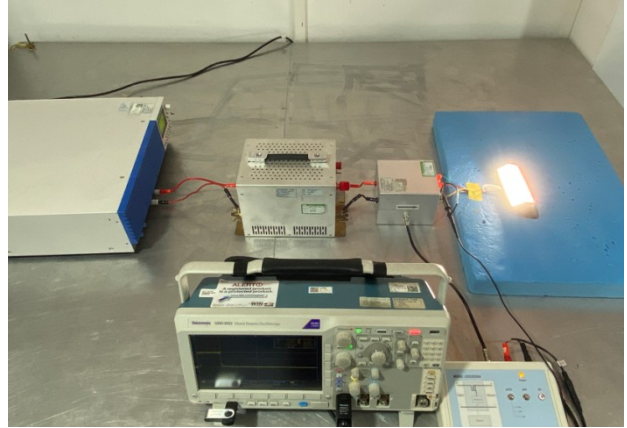

Lugar de ensayo/ *Test place* : SQT, Guangzhou(China)
Fecha de ensayo/ *Test date* : 08/06/2023

THE TESTS HAVE BEEN CARRIED OUT BY IDIADA AUTOMOTIVE TECHNOLOGY, S.A. (TS) LABORATORY ACCREDITED BY ENAC WITH NUMBER OF ACCREDITATION 35/LE2594
LOS ENSAYOS HAN SIDO REALIZADOS POR IDIADA AUTOMOTIVE TECHNOLOGY, S.A. (TS) ACREDITADO POR ENAC CON NÚMERO DE ACREDITACIÓN 35/LE2594

Validate this report with the security code «1LGN2IW8» at: <https://extranet.idiada.com/hom-cve>
Verifique el informe con código de seguridad «1LGN2IW8» en: <https://extranet.idiada.com/hom-cve>

Juxiang(Iyrica) Chen
INGENIERO DE HOMOLOGACIONES
HOMOLOGATION ENGINEER

- * LOS RESULTADOS PRESENTADOS SE REFIEREN ÚNICAMENTE A LA MUESTRA ENSAYADA.
THE PRESENTED RESULTS REFER ONLY TO THE TESTED SAMPLE.
- * QUEDA TERMINANTEMENTE PROHIBIDA LA REPRODUCCIÓN PARCIAL DE ESTE INFORME SIN PERMISO EXPRESO DE IDIADA.
THE PARTIAL REPRODUCTION OF THIS REPORT WITHOUT THE PERMISSION OF IDIADA IS COMPLETELY FORBIDDEN.
- * EL LABORATORIO HA CALCULADO LA INCERTIDUMBRE DE MEDIDA ASOCIADA A LOS RESULTADOS.
MEASUREMENT UNCERTAINTY OF THE RESULTS HAS BEEN CALCULATED BY THE LABORATORY.
- * LA REGLA DE DECISIÓN UTILIZADA, SEGÚN LA NORMA ILAC-G8, HA SIDO LA DECLARACIÓN BINARIA DE ACEPTACIÓN SIMPLE
THE DECISION RULE USED, ACCORDING TO THE ILAC-G8 STANDARD, WAS THE BINARY STATEMENT FOR SIMPLE ACCEPTANCE

DOCUMENTACIÓN TÉCNICA /
TECHNICAL DOCUMENTATION

Information document no. BR0103601 SERIES-00 relating to type-approval of an electronic subassembly with respect to electromagnetic compatibility (ECE Regulation 10.06 to Supplement 2)

Type : BR0103601 SERIES
Date : 2023/06/01
Total pages : 9

Information folder No. : BR0103601 SERIES-00
Manufacturer : Guangzhou Bory Auto Light Co., Ltd.
Regulation : R10.06 to Supplement 2

INDEX

- 2 Index
- 3 General
- 5 Drawings of the ESA
- 7 Electronic block diagram
- 9 List of components constituting the ESA

Information folder No. : BR0103601 SERIES-00
Manufacturer : Guangzhou Bory Auto Light Co., Ltd.
Regulation : R10.06 to Supplement 2

GENERAL

1. Make (trade name of manufacturer):
BORY AUTO LIGHT

2. Type: **BR0103601 SERIES**
Variants: **BR01036XX(XX:00~99)**

Above variants have the same electronic circuit design and the same component list for each PCB, the differences among them are model name and light color .

General commercial description(s):
Special Warning Lamp/Signal Lamp

3. Means of identification of type, if marked on the component/separate technical unit ⁽¹⁾:
Approval mark

3.1 Location of that marking:
Stuck on the enclosure, See Drawings of the ESA

4. Name and address of manufacturer:
Guangzhou Bory Auto Light Co., Ltd.
4/F, Building 8, No.2 Ke'er Road(Self compiled), Dongyong Town,
Nansha District, Guangzhou, Guangdong 511443, China.

Name and address of authorised representative, if any:**N/A**

5. In the case of components and separate technical units, location and method of affixing of the approval mark:
Stuck on the enclosure, See Drawings of the ESA.

6. Address(es) of assembly plant(s):
Guangzhou Bory Auto Light Co., Ltd.
4/F, Building 8, No.2 Ke'er Road(Self compiled), Dongyong Town,
Nansha District, Guangzhou, Guangdong 511443, China.

7. This ESA shall be approved as a component/STU².

8. Any restrictions of use and conditions for fitting:
N/A

9. Electrical system rated voltage:
DC 12V/24V, positive/negative² ground.

Appendix 1: Description of the ESA chosen to represent the type (electronic block diagram and list of main component constituting the ESA (e.g. make and type of microprocessor, crystal, etc.).

See electronic block diagram and list of main component constituting the ESA for details.

Appendix 2: Relevant test report(s) supplied by the manufacturer from a test laboratory accredited to ISO 17025 and recognized by the Type Approval Authority for the purpose of drawing up the type approval certificate.

N/A

Only applicable for charging systems: **N/A**

10. Charger:

N/A

11. Charging current:

N/A

12. Maximal nominal current (in each mode if necessary) :

N/A

13. Nominal charging voltage:

N/A

14. Basic ESA interface functions:

N/A

15. Minimum R_{scE} value (see paragraph 7.11. of this Regulation):

N/A

1. If the means of identification of type contains characters not relevant to describe the component or separate technical unit types covered by this information document, such characters shall be represented in the documentation by the symbol "?" (e.g. ABC??123??).

2. Delete where not applicable.

Information folder No. : BR0103601 SERIES-00
 Manufacturer : Guangzhou Bory Auto Light Co., Ltd.
 Regulation : R10.06 to Supplement 2

Drawings of the ESA

Location of the ECE approval mark

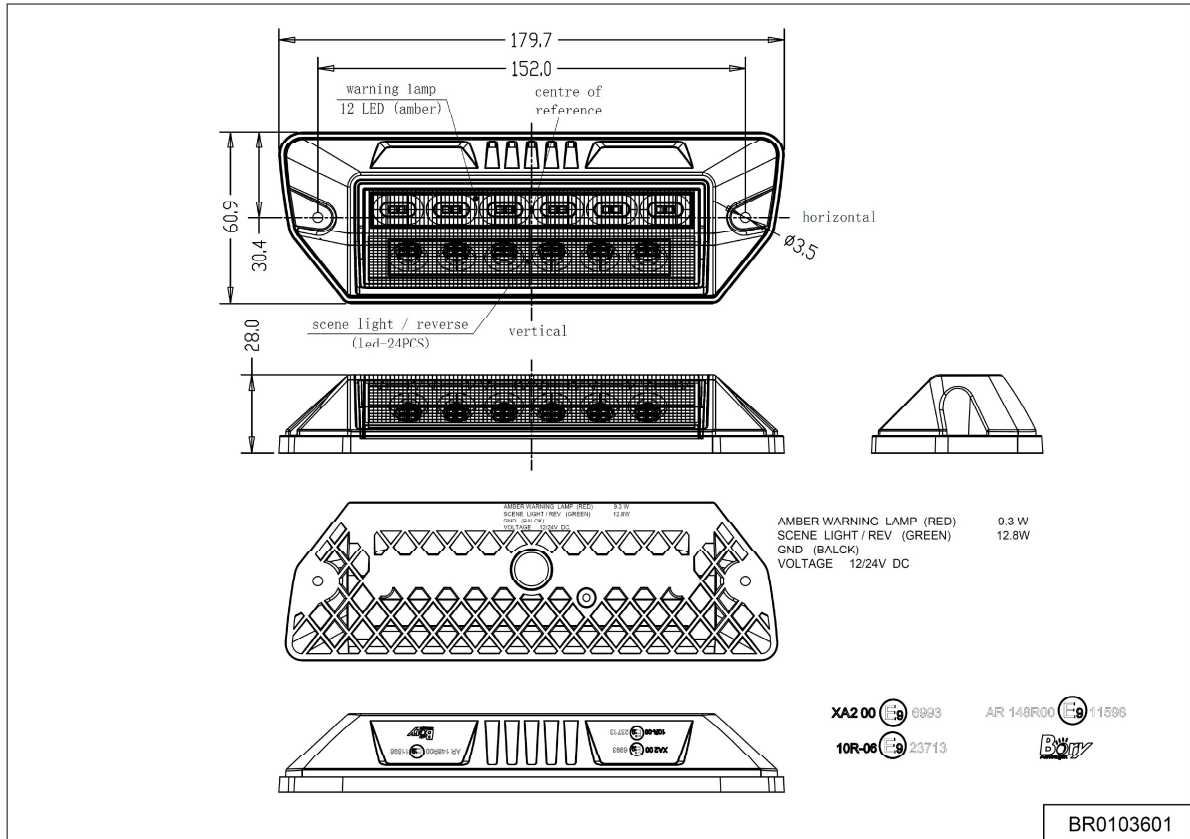

Information folder No. : BR0103601 SERIES-00
 Manufacturer : Guangzhou Bory Auto Light Co., Ltd.
 Regulation : R10.06 to Supplement 2

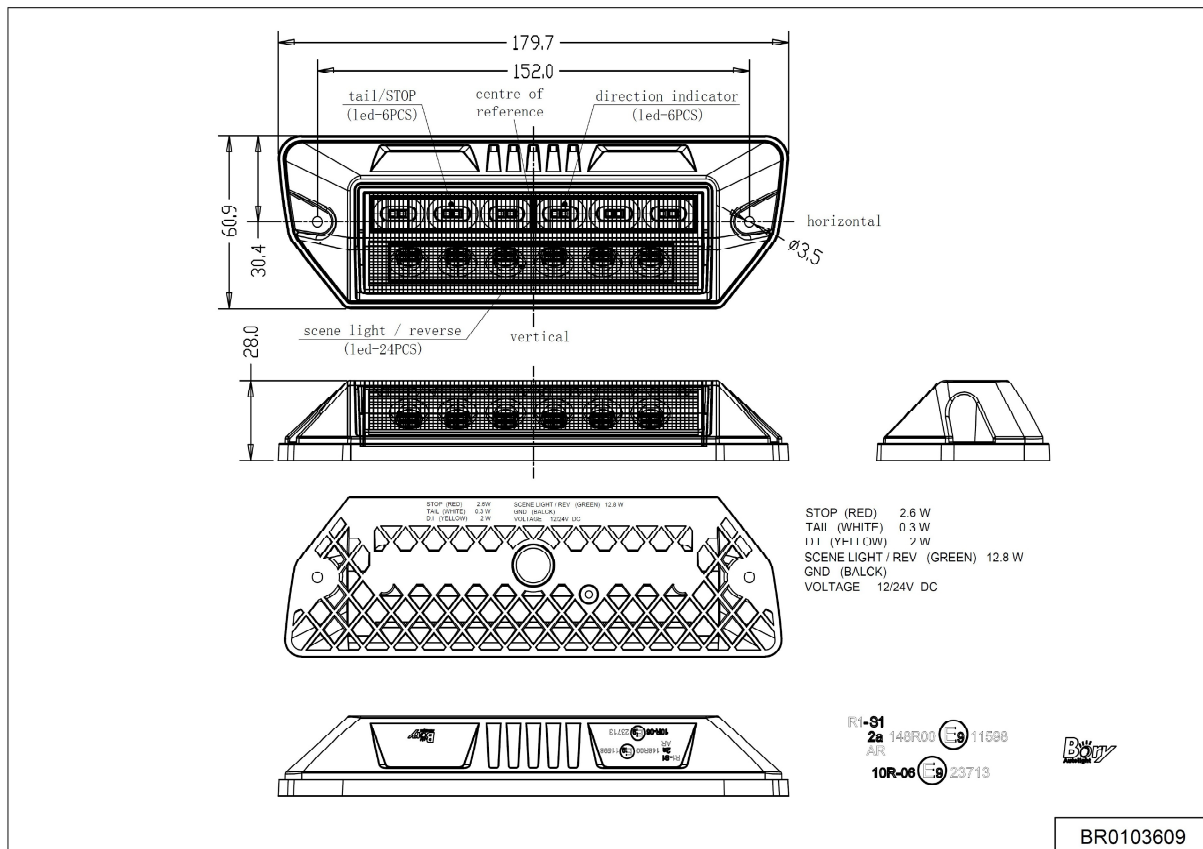
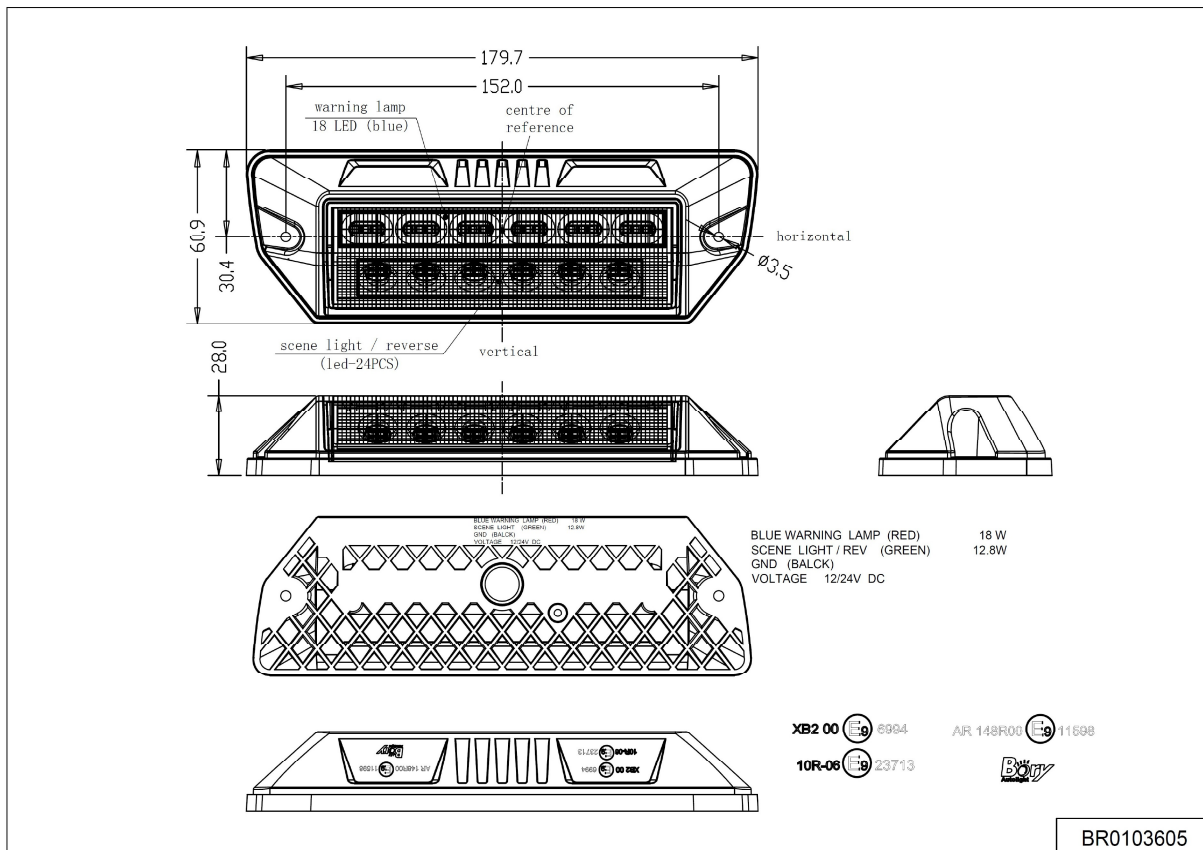

iDiADA CN23060007

Electronic Block Diagram

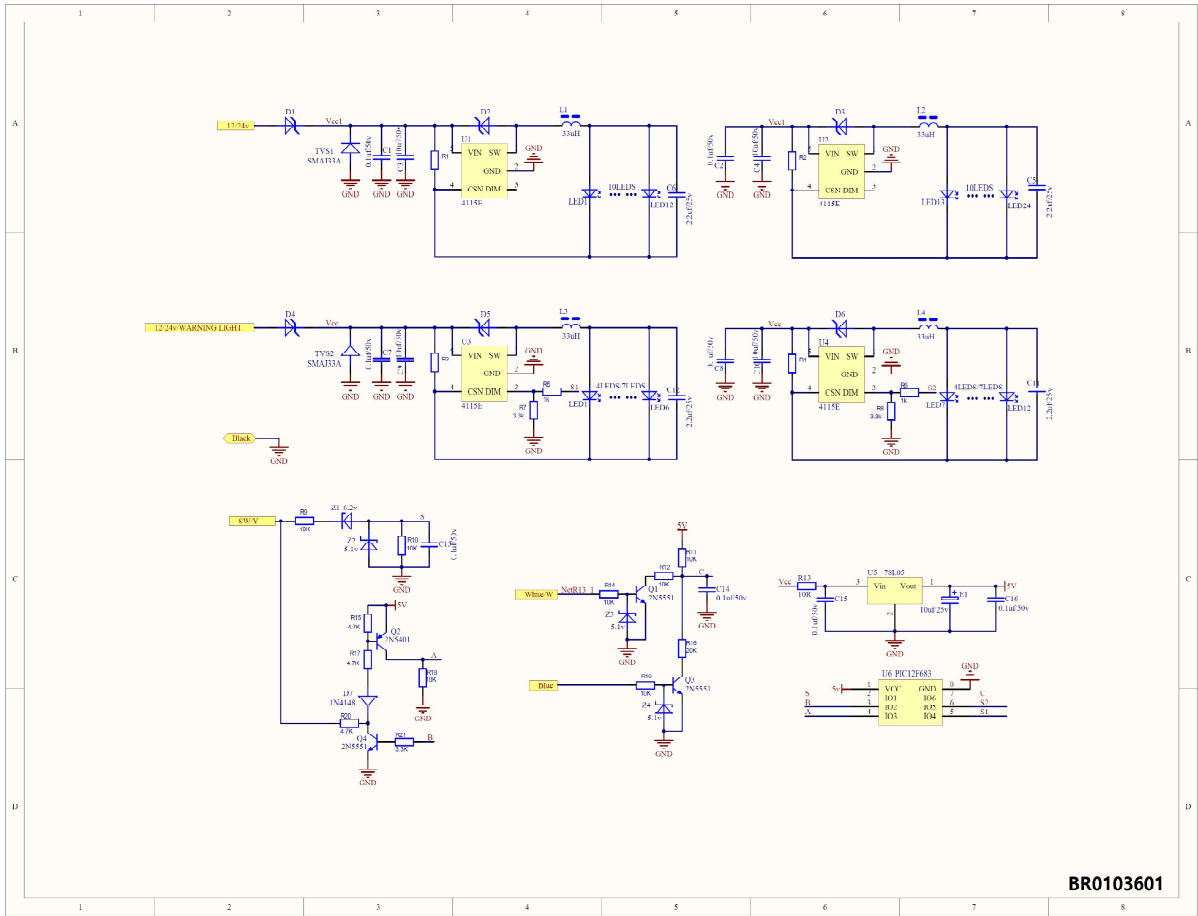

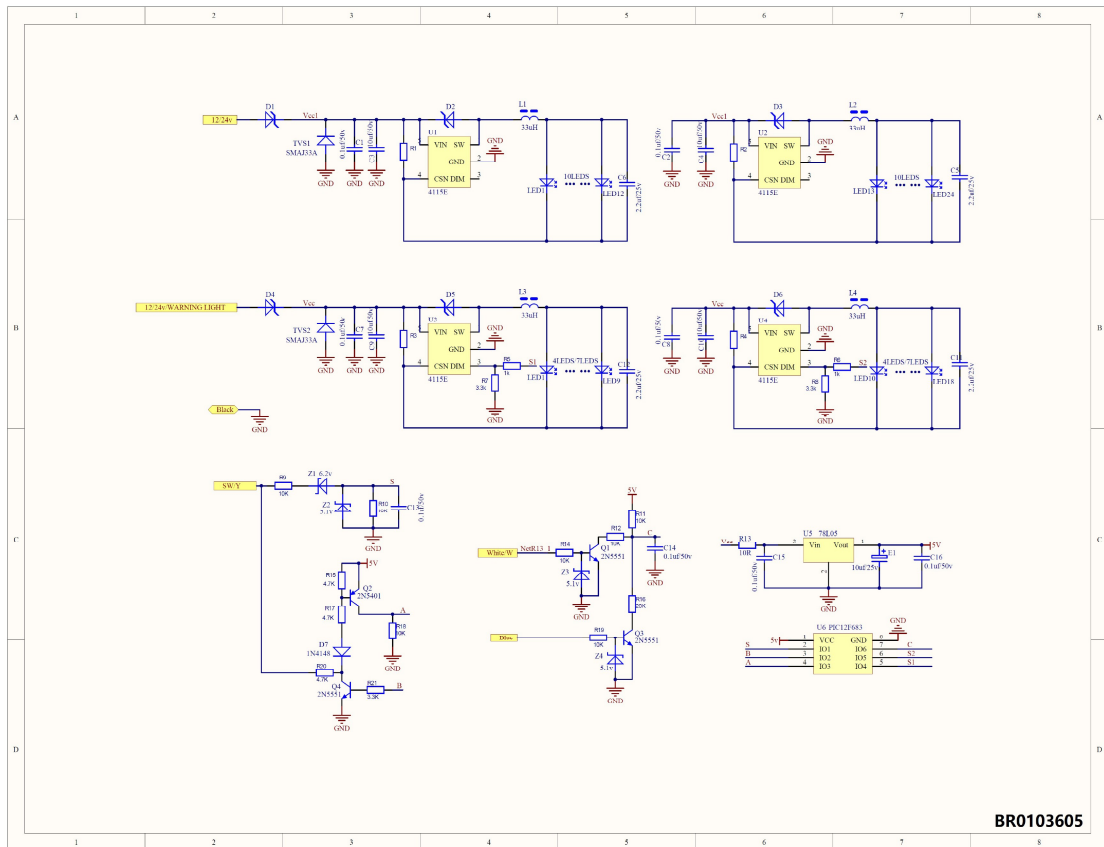

BR0103605

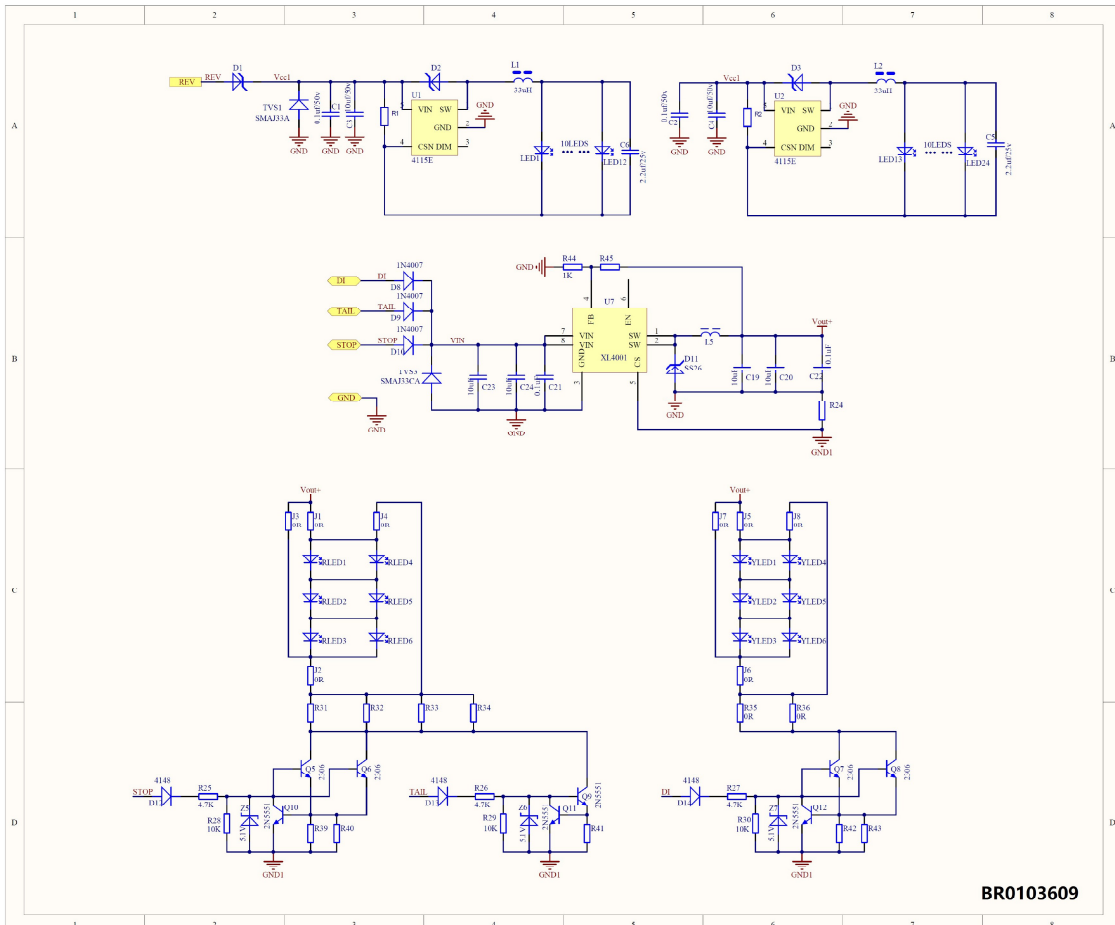

BR0103609

Information folder No. : BR0103601 SERIES-00
 Manufacturer : Guangzhou Bory Auto Light Co., Ltd.
 Regulation : R10.06 to Supplement 2

List of main component constituting the ESA

BR0103601& BR0103605			
No	Component	Specification	quantily
1	LED	1W,2835,9V	/
2	LED	1W,2835,9V,WHITE	24
3	IC	PT4115	4
4	IC	78L05	1
5	Transistor	2N5551,sot-23	3
6	Transistor	2N5401,sot-23	1
7	Capacitor	10uF, 50v, 1206	/
8	Diode	1N4148, SOD-523	1
9	Inductance	33uh, LCE540S330M	/

BR0103609			
No	Component	Specification	quantily
1	LED	0.5W,2835,RED	6
2	LED	0.5W,2835,AMBER	6
3	LED	1W,2835,9V,WHITE	24
4	IC	XL4001,ESOP-8	1
5	IC	PT4115	2
6	Transistor	LCEAJCMA,DO-214AC	2
7	Capacitor	2.2uF, 25v, 0805	2
8	Diode	LCEWT8286, SOD-523	3
9	Inductance	33uh, LCE540S330M	2